

■ **CRYSTALITE (XL)**

- Durable polycarbonate lens
- Slim design
- Integrated switch
- Surfaced or recessed

Internal View

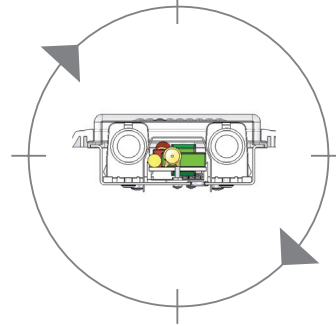

|| See technical specifications overleaf >>>

## CRYSTALITE (XL)

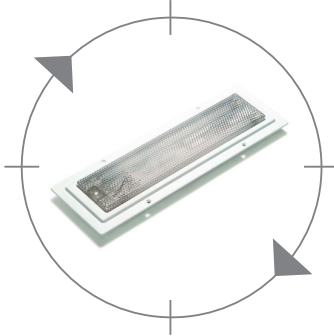

The Crystalite range has been designed to offer a strong but cost effective light unit suitable for use in a variety of applications from motorhomes and marine applications through to vans and trucks. This light unit is available in both surfaced mounted and recessed versions, both of which are supplied with a white fixing plate/surround which provides external mounting holes. The slim design of this light unit allows for ultimate headroom preservation; the surface mounted unit is only 34mm in height. Supplied complete with two 8W fluorescent tubes, this light unit provides a high light output, low current drain light unit for use with either a 12V or 24V DC power source. The chassis is fabricated from an aluminium sheet and this secures both the inverter and the fluorescent tubes. A clear, diamond patterned shade covers the chassis and also incorporates an on/off push switch.

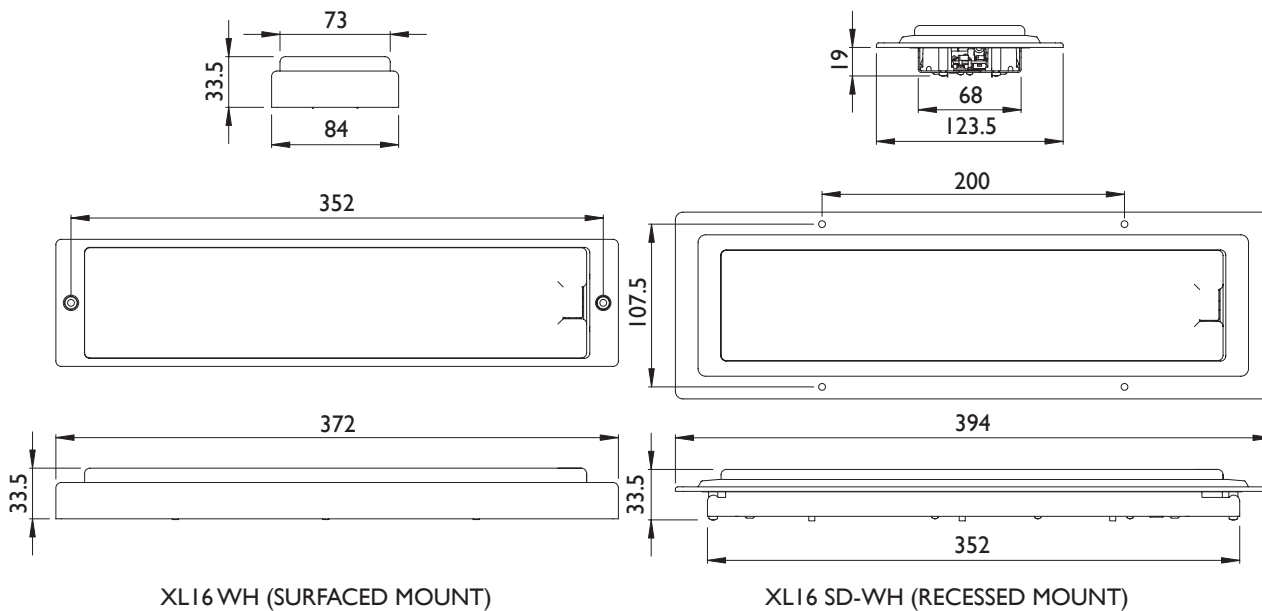

XL16 WH (SURFACED MOUNT)

XL16 SD-WH (RECESSED MOUNT)

### SPECIFICATION

ALL DIMENSIONS HAVE A TOLERANCE OF +/- 1mm

CRYSTALITE (XL)

Model No		XL16	XL16/2	XL16 SD	XL16/2 SD
Supply Voltage	Vdc	12	24	12	24
Voltage Range	Vdc	10 to 15	20 to 32	10 to 15	20 to 32
Average Current	A	0.85	0.55	0.85	0.55
Crest Factor		2.2	1.6	2.2	1.6
Frequency	KHz	33	25	33	25
Tube Watts	W	16W		16W	
Lumens	Lm	800		800	
Weight	Kg	0.42		0.44	
Temp' Range	°C	-10 to +40		-10 to +40	

E & OE