



GEBRUIKERSHANDLEIDING / USERS MANUAL
BETRIEBSANLEITUNG / MODE D'EMPLOI

MASS 12/30-2, 24/15-2, 24/25-2 battery charger



1	General information	10
2	Safety guidelines & measures	10
3	Technical data	11
4	Technology	11
5	Installation	12
6	Operation	14
7	Batteries	14
8	Trouble shooting	15
9	Maintenance	16
10	EC declaration of conformity	16
11	Data sheets	Appendix A
12	Installation sheet	Appendix B

1 GENERAL INFORMATION

GARANTEE SPECIFICATIONS

Mastervolt guarantees the performance of this Mass charger according to the specifications given in the data sheets, if installed and used as described in this manual. Should work take place, which is not in accordance with the guidelines, instructions and specifications contained in this user's manual and the supplementary installation manual, then damage may occur and/or the unit may not fulfil its specifications. All of these matters may mean that the guarantee may become invalid.

The guarantee period is two years.

QUALITY

During their production and prior to their delivery, all of our units are exhaustively tested and inspected.

LIABILITY

Mastervolt can accept no liability for:

- damage due to use of the battery charger;
- possible errors in the manual and the results thereof.

2 SAFETY GUIDELINES & MEASURES

USE FOR INTENDED PURPOSE

The battery charger is constructed as per the applicable safety-technical guidelines. Use the battery charger only:

- for the charging of lead acid batteries and the supply of users attached to these batteries, in permanent systems;
- connected to a dedicated double pole circuit breaker (MCB);
- with a fuse, protecting the wiring between charger output and battery;
- in a technical correct condition;
- in a closed, well-ventilated room, protected against rain, moist, dust and not condensing circumstances.



Never use the battery charger at locations where there is danger of gas- or dust explosion!

Use other than as mentioned under 2 is not considered to be consistent with the intended purpose. Mastervolt is not liable for any damage resulting from the above.

SAFETY

- 1 Use only fuses with the prescribed current level:
 - AC supply fuse not greater than is required for the current consumption;
 - The charger fuse must be large enough for the maximal charger current and small enough to protect the charger's output cables.

- 2 Check the wiring at least once a year. Defects such as loose connections, burned cables etc. must be corrected immediately.
- 3 Do not work on the charger or the system if it is still connected to a current source. Only allow changes in your electrical system to be carried out by qualified electricians.
- 4 Connection and protection must be done in accordance with local standards.
- 5 Before opening the cabinet of the charger, switch off the 230V mains and remove the charger fuse.

MAINTENANCE & REPAIR

If the battery charger is switched off during maintenance and/or repair activities, it should be secured against unexpected and unintentional switching on:

- switch off the AC circuit breaker;
- disconnect the charger;
- switch off the connection with the batteries or remove the charger fuse;
- be sure that third parties cannot reverse the measures taken.

If such are required, use only original spare parts.

3 TECHNICAL DATA

GENERAL

Model	MASS 12/30-2	MASS 24/15-2	MASS 24/25-2
Function apparatus	battery charger/rectifier		
Manufacturer	Mastervolt, Amsterdam		

INPUT

Voltage	230V, -10% +15%	230V AC, -10% +15%	230V, -10% +15%
Frequency	50/60 Hz, \pm 5 Hz	50/60 Hz, \pm 5 Hz	50/60 Hz, \pm 5 Hz
Current	2.5A	2.5A	3.6A
Power factor	1	1	1
Efficiency	88%	88%	88%

OUTPUT

Output voltage	nominal: 12V DC	nominal: 24V DC	nominal: 24V DC
Output current (total max)	30A	15A	25A
Outputs	2 (1x30A max. 1xA max.)	2 (1x15A max. 1x3A max.)	2 (1x25A max. 1x3A max.)
Charge characteristic	three-step, fully automatic, IUoUo		
Kind of batteries	open and sealed lead acid batteries / wet or gel		
Charge voltages (depending of phase)	14.4V-13.25V	28.7V-26.5V	28.7V-26.5V
Ripple voltage	max. 100mV rms, resistive load, full power		
Current	30 Amps	15 Amps	25 Amps
Short circuit current	30 Amps	15 Amps	25 Amps
Polarity control.	polarity protected by means of a breaker		

ENVIRONMENTAL CHARACTERISTICS

Operating ambient temperature	-20 to +40°C; 100% output power
Cooling	forced, by means of a fan with variable speed
Humidity	max. 95% RV, not condensing

ENCLOSURE

Dimensions (hxwx d)	325x220x111 mm
Protection level	IP 23
Weight	2.6 kg
Safety	IEC 335-2-29

4 TECHNOLOGY

INTRODUCTION

The MASS battery charger is a fully automatic high-efficient battery charger/rectifier, developed and produced by Mastervolt Amsterdam. The MASS series goes with a family of advanced quality battery chargers. Mastervolt distributes these products worldwide. The battery charger possesses an outstanding charging technique in order to charge batteries rapidly, safely and in the same time supply the connected consumers. In addition, the charger is secured against short circuit, overload and high temperatures in an industrial environment.

THEORY OF OPERATION

The MASS battery charger has a three-step charge characteristic (see fig. 1).

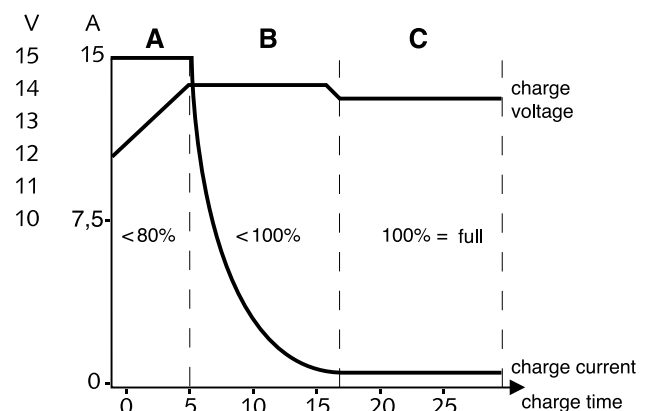

Fig. 1 Example:
Charge characteristic MASS 12/15. (For other models V/A according to data sheets).

Phase 1: Main charge (“BULK”)

The first step “BULK” starts after switching on the MASS charger. In this phase, the charger supplies the maximum current until the battery reaches 14.40V. The battery is now 80% charged. When the battery reaches this limitation area the charge current will decrease. Bulk duration is maximum 6 hours, depending on the battery's condition and charge rate. The yellow “bulk” LED on the front panel will light up during this phase.

Phase 2: “ABSORPTION”

The second step “ABSORPTION” begins automatically with a voltage of 14.25V. The current consumption in the absorption mode is depending on the capacity of the batteries and will decrease slowly. The charger remains in this “absorption” phase until the charge current drops for a period of 15 minutes below 2.5A. If the charge current will not drop below 2.5A, a clock will switch the “absorption” mode off after 6 hours. During the absorption phase the yellow “ABSORPTION” LED on the front panel will light up.

Phase 3: Trickle charge (“FLOAT”)

The third stage, “FLOAT”, starts when the “absorption” phase has been completed. In the “float” mode, the charger automatically switches back to a lower output voltage of 13.25V. This voltage is sufficient to maintain the battery at a 100% charge. During this phase, the capacity of the charger can be entirely used for the supply of the users connected to the battery. During this mode the yellow “float” LED will light up. If necessary the charger automatically switches back to the “absorption” mode.

Current consumption from mains or generator

The charger produces no phase shift, because the input current follows the AC voltage waveform so a power factor of 1.0 or “unity” is achieved. The shape of the input current waveform is the same as the input voltage e.g. sinusoidal. Therefore the input current is very low compared to conventional chargers.

Low ripple on output

The charger has a very low ripple on the output, which prevents interference in the DC circuit. The ripple is less than 100 mV with maximum output current.

Automatic compensation of charge voltage with battery temperature

If the temperature sensor is connected the MASS charger will charge its output voltage $-30\text{mV}/^{\circ}\text{C}$ (12V) or $-60\text{mV}/^{\circ}\text{C}$ (24V). The temperature sensor should give a good interpretation of the battery temperature.

Automatic voltage sense compensation

The charger compensates automatically for the normal voltage drop across the cable connection to the battery.

The charger has been programmed in such a way that a separate sense connection to the battery is not necessary.

CHARGING TWO OR MORE BATTERIES VIA ONE OUTPUT

If two or more batteries need to be charged at the same time and output, a battery isolator should be used. The battery isolator divides the various battery sets from one other, in order to avoid one set discharging the other. Because there is always a voltage drop across the isolator of 0,7V the output voltage needs to be compensated. You can compensate this voltage drop by removing the “diode compensation” jumper on the front panel.

CHARGING A CRANKING BATTERY

In certain situations, it may occur that in addition to the main battery(ies) a cranking battery with the same voltage is used. The battery charger can charge a cranking battery at the same time as the main battery, by using the 3A output.



The second output has the same output voltage as the main output, 3 Amps maximal !

THE BATTERY CHARGER AS FLOAT CHARGER

It is possible to use the charger as a “trickle” charger. The charger then supplies a constant output voltage of 13.25V (26.5V). For this mode you can remove a jumper on the front.

SELECTION WET OR GEL BATTERIES

The optimal charge voltage for a wet lead acid battery differs from the gel battery. Therefore it is possible to switch over to a higher float voltage (13.8V for 12V and 27.6V for 24V) necessary for gel batteries. You increase this output voltage by removing a jumper on the front panel.

5 INSTALLATION

Install the MASS battery charger in a dry, well ventilated area, as close as possible to the batteries. Although the battery charger has a high efficiency, some heat will be produced. This heat will be discharged by a fan with variable speed. At installation of the battery charger be sure that:

- the air flow is not obstructed;
- no water and/or dust can enter the cabinet.

MOUNTING THE MASS CHARGER

The charger can be either horizontal or vertical mounted. We recommend vertical, because the heat convection is from bottom to top.

WIRING AND CONNECTIONS

When connecting any auxiliary equipment and/or a battery isolator, proceed as follows:

- switch off the charger;
- switch off the AC mains or generator supply;
- isolate the DC distribution from the battery.

Battery wires

Keep the cable connection between charger and battery as short as possible. If possible use coloured battery cables. If this is not possible, mark the plus and the minus cables with coloured insulating tape, e.g. red for plus and blue for minus. Use the following diameters:

length up to 3 meter	length above 3 meter
6 qmm	10 qmm

Connection of main batteries

The minus cable (blue) on the -battery (minus connection) of the battery charger. The plus cable (red) on the + main battery (plus-connection) of the charger.

The other side of the cable has to be connected to the battery or the DC distributor. The minus cable (blue) on the min-connection of the battery or DC divider. The plus cable (red) on the plus-connection of the battery or DC divider.



Reversing the plus and the minus will blow the fuse near to the minus connector (the red LED above the fuse will light up). Before you replace the fuse check the polarity of the connections. Replace the fuse only for a 20A fuse.



Too thin cables and/or loose connections can cause dangerous overheating of the cables and/or terminals. Therefore tighten all connections properly, in order to limit as much as possible transition resistance, and use the battery cables with the correct diameter.

Battery isolator

If one or more batteries or battery sets must be charged at the same time via one output, a battery isolator should be used. A battery isolator isolates the different battery sets from one another, in order to prevent one discharging the other. A consequence of the battery isolator is a voltage drop of 0.7 Volt. This voltage drop can be compensated by removing a jumper on the front panel of the charger.

Choose isolator type:

2 battery set	3 battery set
MV 702	MV 703

For proper installation, see the connection diagram included with the battery isolator.

Steps:

- 1 Check if the charger, the main supply and the DC divider are switched off.
- 2 Connect the battery isolator(s) using cables with the same diameter as the battery cables.
- 3 Compensate the voltage drop over these diodes by removing the "diode compensation" jumper on the front of the charger.
- 4 Switch the charger on.

Connection of cranking battery (3A output)

The distance between charger and cranking battery determines the required, minimal cable diameter. For cable lengths up to 6 meters 2,5 qmm must be used. When using long thin cables, it will take proportionately longer before a cranking battery is entirely charged. Therefore use, for longer distances, a larger diameter. The maximal charging current for the cranking battery is 3A. The charging current for the main battery will in this case be 3A lower.

- Connect the minus of the cranking battery to the minus of the main battery.
- Connect the plus of the cranking battery to the "BAT2" plus terminal of the charger.

AC power supply

Check the voltage of your mains source or generator. This must be between 190 and 250 VAC.

Connect the mains cable on one side on the MASS charger and the opposite side to the mains or generator.

ACCESSORIES

When connecting accessories, first switch the charger „OFF" and disconnect from AC.

Temperature sensor

Mount the sensor at a location that gives a good indication of the battery temperature. Plug the connection cable into one of the input jacks of the charger.

Basic remote panel

Plug the connection cable into the analog input jack.

Standard remote panel

Plug the connection cable into the digital input jack. The communication protocol is based on quasi RS 232.

Adjustment Interface & advanced remote panel

Plug the connection cable into the digital input jack. The communication protocol is based on quasi RS 232.

ADJUSTMENTS

On the front of the charger you find three jumpers, each for a specific application. You can easily remove the jumpers with a pincet or a small pincer.

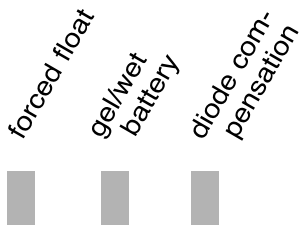

Forced float

For industrial applications only.

Gel/wet battery

By removing this jumper the output will be a constant “trickle charge” voltage of 13,8V.

Diode compensation

By removing this jumper the output voltage will be increased with 0,7 Volt.

6 OPERATION

- 1 Check if the charger is „OFF”.
- 2 Connect DC output with batteries or place fuse.
- 3 Switch on AC source.

Switching on:

The MASS charger will be switched on by the ON switch. One of the front LEDS will light up now and the charging starts immediately.

INDICATOR LIGHTS

FLOAT:

The battery charger is in a “trickle charge” mode, batteries are 100% charged.

ABSORPTION:

The batteries are still charging, charge level is approx. 80%.

BULK:

The charger supplies the maximal voltage, the battery charge is less than 80%.

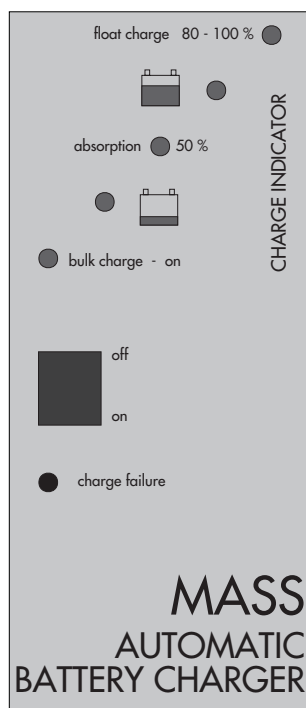

Switching off:

The IVO charger will be switched off by the OFF switch.

7 USING THE CHARGER WITH YOUR BATTERIES

CHARGING EFFICIENCY

For a good performance your batteries should not be discharged below 30-40% of their capacity. Therefore always start charging at this level.

As in marine and mobile systems often a limited charging time is desired, batteries are with generator use charged up to 85-90%. Charging up to 100% would take too long. This means that normally about 50% of the theoretical battery capacity can be used.

In case a mains connection is present, charging time is less important. Then charging up to 100% is advised.

TIPS TO INCREASE THE BATTERY LIFETIME:

- Install the batteries at a cool place. The acid in the batteries will damage the plates in a high temperature environment. A normal life time of 5 year at 20°C, will go down to 2.5 years at 30°C.
- Charge the battery immediately after a consistent deep discharge. Especially at high environment temperatures, sulfating occurs very fast. If the state of sulfating is not too bad, the battery will regain a part of its capacity after a number of charge/recharge cycles.

8 TROUBLE SHOOTING

Malfunction	Possible cause	What to do
No output voltage and/or current	No AC mains or fuse blows	Check fuse, replace if necessary.
	Mains or generator output too low	Check input voltage, must be between 190 and 260V (nominal 230V).
Output voltage too low but charger supplies max. current	Battery load consumes more than the charger can supply, the battery voltage cannot increase more	Reduce the battery load taken from batteries.
	Batteries not 100% charged	Measure the battery voltage after a while, this will be higher.
Charge current too low	Batteries almost fully charged	Check if the charger is in the absorption mode. In this mode, the charge current will slowly decrease.
	High ambient temperature	If the ambient temperature is more than 40°C, the maximum charge current automatically will be reduced.
	Mains too low	When the mains is lower than 190V, the charger will regulate the current down.
Batteries not fully charged	Charge current too low Current to load too high Charge time too short Battery temperature too low Defective battery (short circuit in cell) Defective battery charger	See "charge current too low"; Decrease the battery load; Increase type of charger; Use temperature sensor; Replace the battery; Check the charger.
Battery very fast empty	Battery capacity reduced because: <ul style="list-style-type: none"> • wastage • sulphating/stagnation 	Replace the batteries; Charge/discharge for several times, this might help, otherwise replace batteries.
Batteries are warm/gassing	Defective batteries (short circuit in cell) Battery temperature too high Charge voltage too high	Replace batteries; Use temperature sensor; Check jumper 'battery isolator' on front panel.

If you cannot solve the problem with this fault finding table, contact your Mastervolt Service Centre.
For a detailed distributor list, please contact our main office in Amsterdam, tel. +31-20-3422100.

9 MAINTENANCE

The battery charger requires no specific maintenance. For a reliable and optimal function of the MASS battery charger only the following is required:

- Check at least once a year the wire and cable connections (loosen joints etc.).
- Keep the MASS charger dry, clean and in a dust-free area, in order to ensure a good heat discharge.

10 EC DECLARATION OF CONFORMITY



Manufacturer: MASTERVOLT
Address: Snijdersbergweg 93
1105 AN AMSTERDAM Z.O.
The Netherlands

Herewith declares that:
Product: MASS battery charger
Model: MASS 12/30-2
MASS 24/15-2
MASS 24/25-2

Is in conformity with the provision of the EC EMC directive 89/336/EEC and amendments 92/31/EEC and 93/68/EEC.

The following harmonized standards have been applied:
Generic emission standard EN 50081-1:1992
Generic immunity standard EN 50082-1:1992

Amsterdam,



Dr. F.J. ter Heide,
Managing director MASTERVOLT

APENDIX A & B

MASS 12/30-2, 24/15-2, 24/25-2

battery charger



11 DATA SHEETS MASS 12/30-2

MAIN INFORMATION

Design	: by MASTERVOLT
Manufacturer	: ISO 9001 certified
Model / name	: MASS 12/30-2
Product	: battery charger/rectifier
Article no	: 04-00-10300
Colour	: • RAL 5021, wasserblau • RAL 7037, grey
Weight excl. packing	: 2.6 kg
Shipping weight	: 4 kg
Cabinet typ	: MASS 1 cabinet
Dimensions	: hxwxd. 325 x 220 x 111 mm
Carton dimensions	: hxwxd. 350 x 250 x 160 mm
Type of packing	: carton recycable
Available	: 230V / 50-60Hz
Availability	: normally from stock, from July '99 onwards



Mass 12/30-2 battery charger/rectifier, art.no 04-00-10300, in new 'high tech' enclosure.

TECHNICAL SPECIFICATIONS

Function apparatus	: charging of 12V lead acid batteries and power simultaneously loads
Nominal input voltage	: 230V AC, 1ph, 3wire, 50/60 Hz
Input voltage range full specs	: 190..250V, 50/60 Hz, \pm 5%
Input voltage range no-defects	: 0..250V, 33-80 Hz
Input current	: at 230V AC: 2.5A
Inrush current	: no inrush current, soft start, according to IEC 1003-3
Power factor	: 1, power factor controlled, IEC 555-2
Max. input power	: 550 Watt
Efficiency	: > 88%
Output voltage	: nominal 12V DC
Output current	: nominal 30 Amps
Charge characteristic	: three-step, fully automatic, IUoUo, programmable
Kind of batteries	: open & sealed lead acid batteries
Charge voltage 25°C	: • bulk voltage 14.40V • absorption 14.25V • wet float 13.25V • gel float 13.8V
Return Amps	: 2.5A
Min. Absorption time	: 15 minutes
Max. Bulk/abs. time	: 6 hours
Return new cycle voltage	: 12.8V, delay 30 seconds
Temperature compensation	: 30 mV/°C, by temperature sensor
Voltage sense	: fully automatic compensation
Ripple voltage	: max. 100mV rms, resistive load, full power
Voltage accuracy	: voltage \pm 2%
Current accuracy	: current \pm 3%
Maximum output	: • 30 Amps at 14.25 Volt at 25°C ambient • 30 Amps at 13.25V at 40°C ambient
DC leakage drain	: < 10 mA
Number of outputs	: one main outputs and one 3 Amps Slave Charger
AC/DC connections	: internal, min. AC cable size: 2.5 mm ² / min. DC cable size: 16 mm ²
Jumper selections	: • gel/wet battery selection • forced to float • battery isolator compensation
Remote indication	: status bulk, absorption, float
Remote connection	: by telephone plug-in jack - RJ45
Temperature connection	: by telephone plug-in jack - RJ45
Smart controls	: QRS232 output by telephone plug - RJ45

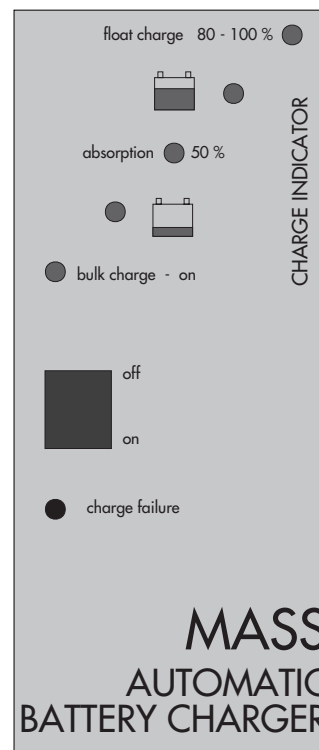

Standard control on unit.

TECHNICAL SPECIFICATIONS

Short circuit protection	: yes, reduced output max. 30 Amps
Reverse polarity protection	: yes, by internal fuses
Over heat	: yes, derating output and shut off by 80°C temperature on heatsink
Storage temperature	: -25°C to 80°C
Operating ambient temperature	: -20°C to 40°C, derating with 2.5% / °C > 40°C
Humidity	: maximum 95%, not condensing
Vibration	: according IEC 68-2-6
Cooling	: mix of conventional and forced air cooling
Forced cooling	: by one variable speed maintenance free DC fan
Environmental protection	: IP23
Reliability/life time	: • MTBF 30.000 hours • 1/4 life time period, $U_{in} = 207V$ AC, $U_{out} = 14,25$, $I_{out} = 30$ Amps at $T_{amb} 40^{\circ}C$ • 3/4 life time period, $U_{in} = 207V$ AC, $U_{out} = 13,25$, $I_{out} = 30$ Amps at $T_{amb} 25^{\circ}C$

ELECTRO MAGNETIC COMPATIBILITY

Electro Magnetic Emission	: better than EN 50081-1 (gen. emission standard, scope; residential, commercial & light industry)
Electro Magnetic Immunity	: better than EN 50082-1 (gen. emission standard, scope; residential, commercial & light industry)
Safety	: according to IEC 335-2-29, polarity protected by means of a breaker, short break

WHAT TO DO IN CASE OF A DEFECT?

- ✓ Consult factory in Amsterdam, tel. +31-20-3422100, or your local Repair Center.

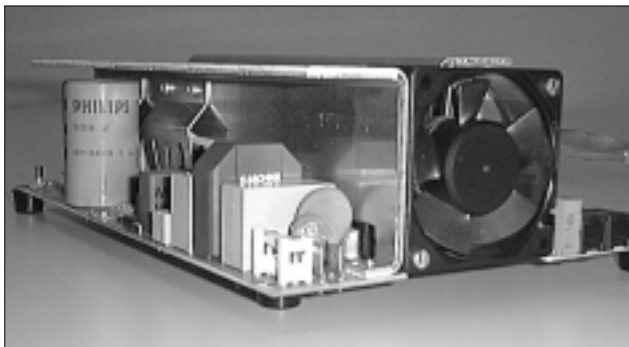

Main PCB of the MASS 12/30-2.

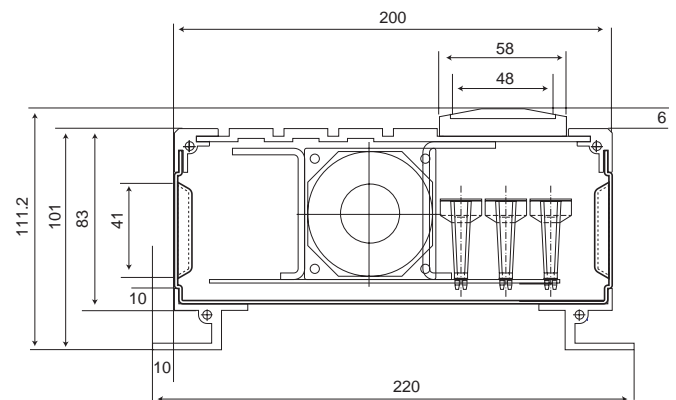

Dimensions of the new cabinet and PCB.

COMPLIANCES

• CE:

Is in conformity with the provision of the EC EMC directive 89/336/EEC and amendments 92/31/EEC, 93/68/EEC.

The following harmonized standards have been applied:

- Generic emission standard : EN 50081-1:1992
- Generic immunity standard : EN 50082-1:1992

• LLOYDS, DNV, ABS:

MASTERVOLT has constructed this product for rugged circumstances in professional or leisure situations. This product can be type-approved individually. Price approx. US \$ 1500 per certification.

• MANUFACTURED UNDER ISO 9001.

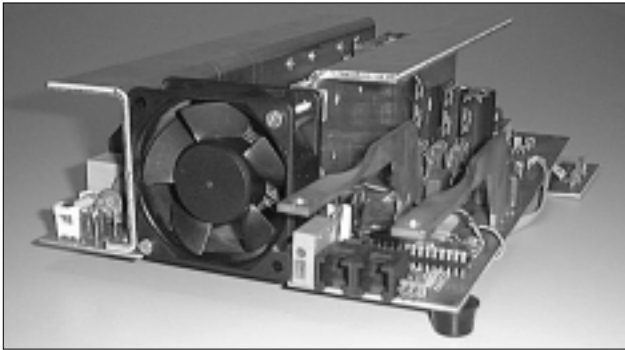

Main PCB of the MASS 12/30-2.

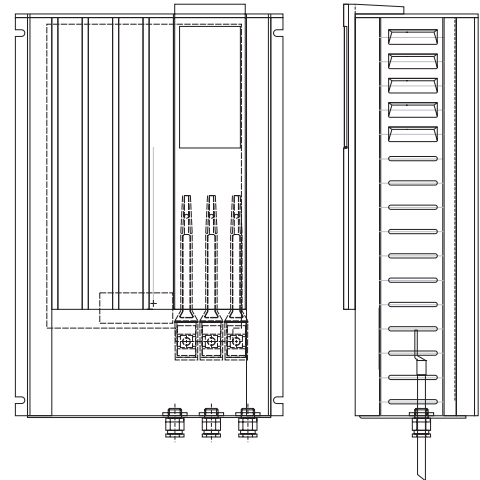

New 'high tech' enclosure.

ACCESSORIES & REMOTES

Article no	description	
04-15-00100	basic remote control	LED's
--	standaard remote contol	LED's current control
--	advanced remote control	display with owner's settings
04-15-00300	MASS 1 temperature sensor	
--	MASS 1 cable set	
--	MASS 1 remote cable set	
00-17-05000	Adjustment Interface	
--	Smart alarm control box	

SERVICE INFORMATION

Article no	description
--	sub assy, main PCB board
--	complete aluminium heatsink
--	cover module
--	connection module
--	front indicator module
--	installation blocks



Adjustment Interface, art. no 02-17-05000.
The below mentioned data can be adjusted with this digital instrument:

- adjustment charge voltage (e.g. traction)
- 'return' Amps etc.

OPERATING PRINCIPLE

Fully automatic power factor switch mode battery charger, suitable as power supply using a separate non-isolated pre regulator boost converter for power factor correction, followed by a double forward converter controlled by a combination of analogue hardware and microprocessor control.

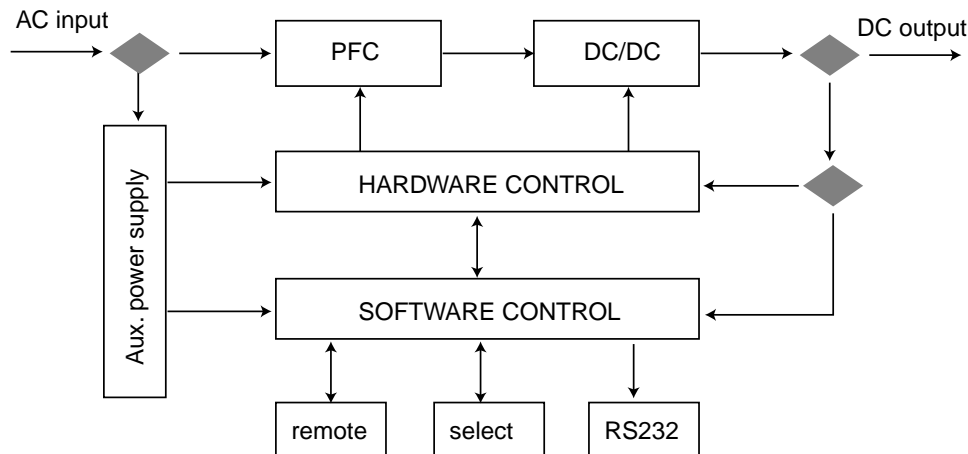

Set points register	Setpoint
1	Min. bulk time 30 sec.
2	Temperature variation 30 mV/C
3	Return to bulk time 30 sec.
4	Return to bulk voltage 12.80 V
5	Max. bulk/abs time 360 min.
6	Min. abs time 15 min.
7	Return Amps 2.5 Amps
8	Max. charge current 30 Amps
9	Bulk voltage 14.40 V
10	Abs voltage 14.25 V
11	Float voltage 13.25 V
12	Forced to float voltage 13.25 V
13	Gel voltage setting 550 mV
14	Diode compensation setting 600 mV
15	DC high alarm on 15.00 V
16	DC high alarm off 14.50 V
17	DC low alarm on 10.00 V
18	DC low alarm off 11.00 V
19	Alarm delay time 30 sec.

- Temperature variation 5.0 mV/°C per cell
- Reference voltage 25°C
- Battery charging is not allowed above +50°C and under -20°C
- 12 Volt 30 mV/°C
- 24 Volt 60 mV/°C

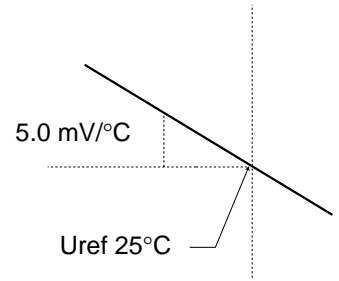

forced float
gel/wet. battery
diode compensation

- standard IUU characteristic
- IUU char. increased with 0.6V
- IUU char. high float level
- IUU char. high float, increased with 0.6V
- IU char. low float level
- IU char. low float, increased with 0.6V
- IU char. high float level
- IU char. high float, increased with 0.6V

TEMPERATURE COMPENSATED CHARGING

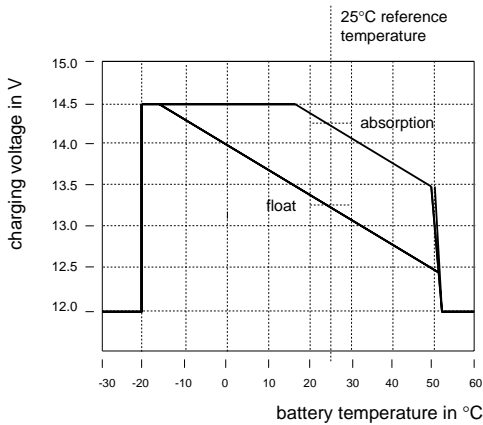

CHARGING CHARACTERISTICS

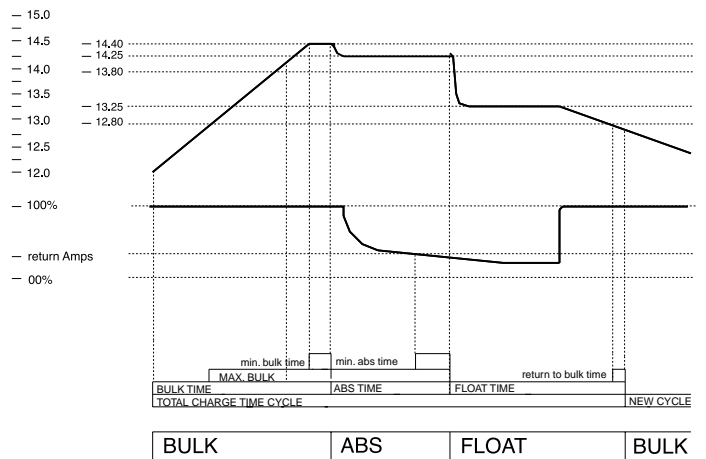

MAX. OUTPUT VERSUS INPUT VOLTAGE

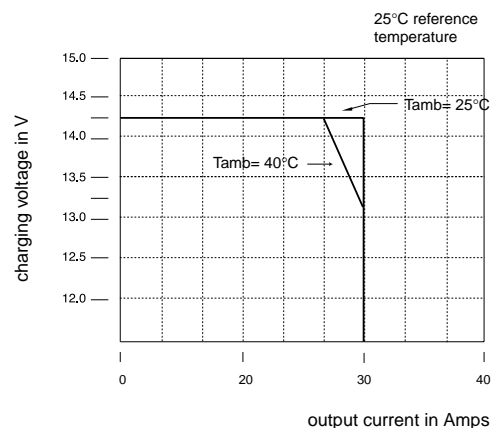
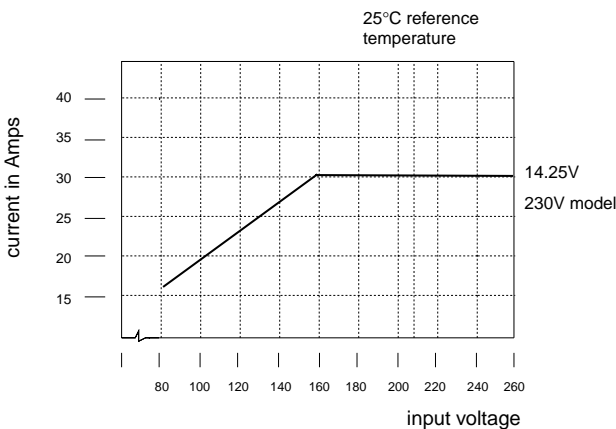

11 DATA SHEETS MASS 24-15-2

MAIN INFORMATION

Design	: by MASTERVOLT
Manufacturer	: ISO 9001 certified
Model / name	: MASS 24/15-2
Product	: battery charger/rectifier
Article no	: 04-00-20150
Colour	: • RAL 5021, wasserblau • RAL 7037, grey
Weight excl. packing	: 2.6 kg
Shipping weight	: 4 kg
Cabinet type	: MASS 1 cabinet
Dimensions	: hxwx. 325 x 220 x 111 mm
Carton dimensions	: hxwx. 350 x 250 x 160 mm
Type of packing	: carton recycable
Available	: 230V / 50-60Hz
Availability	: normally from stock, from July '99 onwards



Mass 24/15-2 battery charger/rectifier, art.no 04-00-20150, in new 'high tech' enclosure.

TECHNICAL SPECIFICATIONS

Function apparatus	: charging of 24V lead acid batteries and power simultaneously loads
Nominal input voltage	: 230V AC, 1ph, 3wire, 50/60 Hz
Input voltage range full specs	: 190..250V, 50/60 Hz, $\pm 5\%$
Input voltage range no-defects	: 0..250V, 33-80 Hz
Input current	: at 230V AC: 2.5A
Inrush current	: no inrush current, soft start, according to IEC 1003-3
Power factor	: 1, power factor controlled, IEC 555-2
Max. input power	: 550 Watt
Efficiency	: > 88%
Output voltage	: nominal 24V DC
Output current	: nominal 15 Amps
Charge characteristic	: three-step, fully automatic, IUoUo, programmable
Kind of batteries	: open & sealed lead acid batteries
Charge voltage 25°C	: • bulk voltage 28.7V • absorption 28.5V • wet float 26.5V • gel float 27.6V
Return Amps	: 1.25A
Min. Absorption time	: 15 minutes
Max. Bulk/abs. time	: 3 hours
Return new cycle voltage	: 25.6V, delay 30 seconds
Temperature compensation	: 60 mV/°C, by temperature sensor
Voltage sense	: fully automatic compensation
Ripple voltage	: max. 100mV rms, resistive load, full power
Voltage accuracy	: voltage $\pm 2\%$
Current accuracy	: current $\pm 3\%$
Maximum output	: • 15 Amps at 28.5 Volt at 25°C ambient • 15 Amps at 26.5V at 40°C ambient
DC leakage drain	: < 5 mA
Number of outputs	: one main outputs and one 3 Amps Slave Charger
AC/DC connections	: internal, min. AC cable size: 2.5 mm ² / min. DC cable size: 16 mm ²
Jumper selections	: • gel/wet battery selection • forced to float • battery isolator compensation
Remote indication	: status bulk, absorption, float
Remote connection	: by telephone plug-in jack - RJ45
Temperature connection	: by telephone plug-in jack - RJ45
Smart controls	: QRS232 output by telephone plug - RJ45

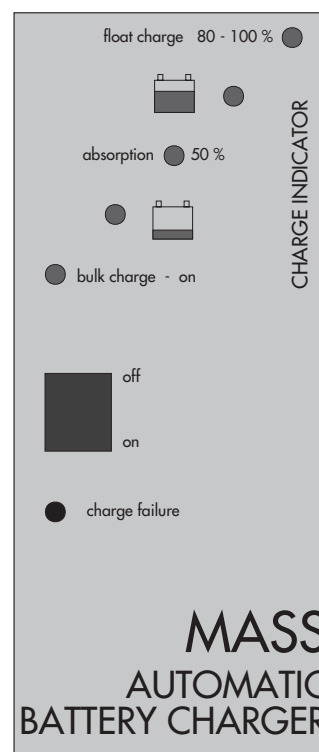

Standard control on unit.

TECHNICAL SPECIFICATIONS

Short circuit protection	: yes, reduced output max. 15 Amps
Reverse polarity protection	: yes, by internal fuses
Over heat	: yes, derating output and shut off by 80°C temperature on heatsink
Storage temperature	: -25°C to 80°C
Operating ambient temperature	: -20°C to 40°C, derating with 2.5% / °C > 40°C
Humidity	: maximum 95%, not condensing
Vibration	: according IEC 68-2-6
Cooling	: mix of conventional and forced air cooling
Forced cooling	: by one variable speed maintenance free DC fan
Environmental protection	: IP23
Reliability/life time	: <ul style="list-style-type: none"> • MTBF 30.000 hours • 1/4 life time period, $U_{in} = 207V$ AC, $U_{out} = 28.5$, $I_{out} = 15$ Amps at $T_{amb} 40^{\circ}C$ • 3/4 life time period, $U_{in} = 207V$ AC, $U_{out} = 26.5$, $I_{out} = 15$ Amps at $T_{amb} 25^{\circ}C$

ELECTRO MAGNETIC COMPATIBILITY

Electro Magnetic Emission	: better than EN 50081-1 (gen. emission standard, scope; residential, commercial & light industry)
Electro Magnetic Immunity	: better than EN 50082-1 (gen. emission standard, scope; residential, commercial & light industry)
Safety	: according to IEC 335-2-29, polarity protected by means of a breaker, short break

WHAT TO DO IN CASE OF A DEFECT?

- ✓ Consult factory in Amsterdam, tel. +31-20-3422100, or your local Repair Center

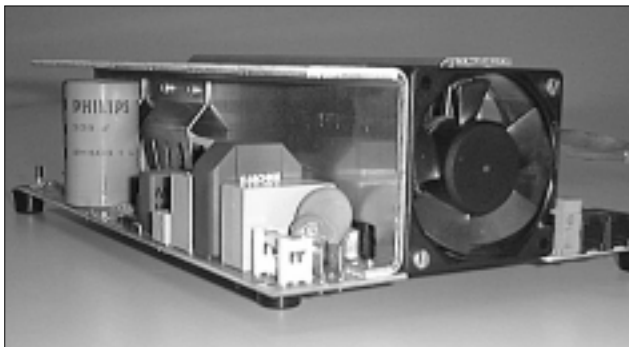

Main PCB of the MASS 24/15-2.

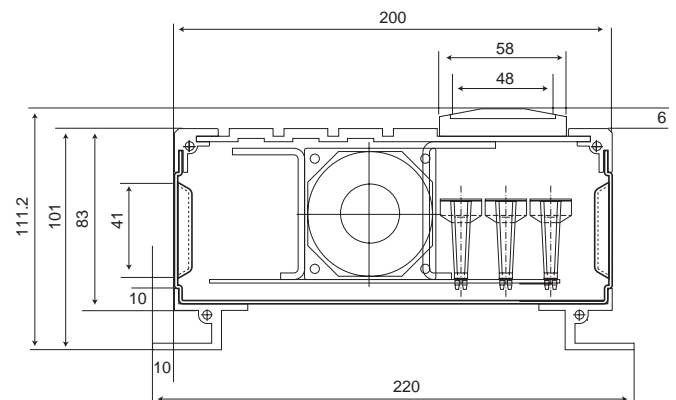

COMPLIANCES

• CE:

Is in conformity with the provision of the EC EMC directive 89/336/EEC and amendments 92/31/EEC, 93/68/EEC.
 The following harmonized standards have been applied:

- Generic emission standard : EN 50081-1:1992
- Generic immunity standard : EN 50082-1:1992

• LLOYDS, DNV, ABS:

MASTERVOLT has constructed this product for rugged circumstances in professional or leisure situations.
 This product can be type-approved individually. Price approx. US \$ 1500 per certification.

• MANUFACTURED UNDER ISO 9001.

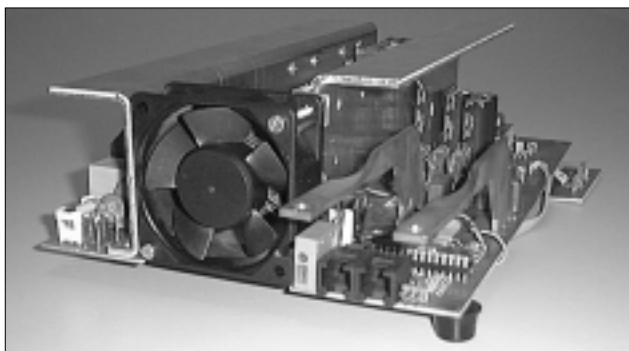

Main PCB of the MASS 24/15-2.

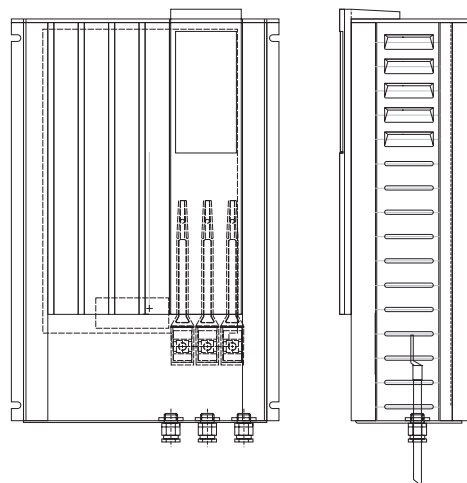

New 'high tech' enclosure.

ACCESSORIES & REMOTES

Article no	description	
04-15-00100	basic remote control	LED's
--	standaard remote contol	LED's current control
--	advanced remote control	display with owner's settings
04-15-00300	MASS 1 temperature sensor	
--	MASS 1 cable set	
--	MASS 1 remote cable set	
00-17-05000	Adjustment Interface	
--	Smart alarm control box	



Adjustment Interface, art. no 02-17-05000.
The below mentioned data can be adjusted with this digital instrument:

- adjustment charge voltage (e.g. traction)
- 'return' Amps etc.

SERVICE INFORMATION

Article no	description
--	sub assy, main PCB board
--	complete aluminium heatsink
--	cover module
--	connection module
--	front indicator module
--	installation blocks

OPERATING PRINCIPLE

Fully automatic power factor switch mode battery charger, suitable as power supply using a separate non-isolated pre regulator boost converter for power factor correction, followed by a double forward converter controlled by a combination of analogue hardware and microprocessor control.

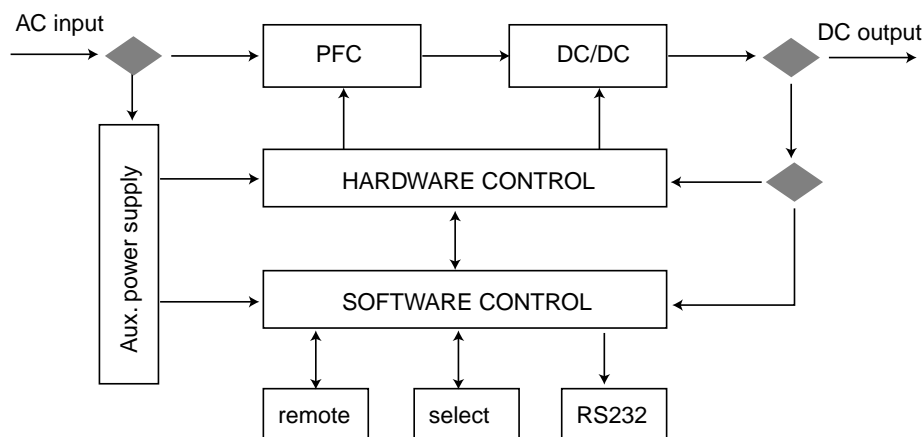

Set points register	Setpoint
1	Min. bulk time 30 sec.
2	Temperature variation 60 mV/C
3	Return to bulk time 30 sec.
4	Return to bulk voltage 25.60 V
5	Max. bulk/abs time 360 min.
6	Min. abs time 15 min.
7	Return Amps 1.25 Amps
8	Max. charge current 15 Amps
9	Bulk voltage 28.70 V
10	Abs voltage 28.50 V
11	Float voltage 26.50 V
12	Forced to float voltage 26.50 V
13	Gel voltage setting 1.10 V
14	Diode compensation setting 600 mV
15	DC high alarm on 30 V
16	DC high alarm low 29 V
17	DC low alarm on 20 V
18	DC low alarm off 22 V
19	Alarm delay time 30 sec.

- Temperature variation 5.0 mV/°C per cell
- Reference voltage 25°C
- Battery charging is not allowed above +50°C and under -20°C
- 12 Volt 30 mV/°C
- 24 Volt 60 mV/°C

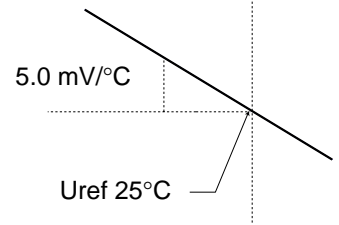

forced float
gell/wet battery
diode compensation

- standard IUU characteristic
- IUU char. increased with 0.6V
- IUU char. high float level
- IUU char. high float, increased with 0.6V
- IU char. low float level
- IU char. low float, increased with 0.6V
- IU char. high float level
- IU char. high float, increased with 0.6V

TEMPERATURE COMPENSATED CHARGING

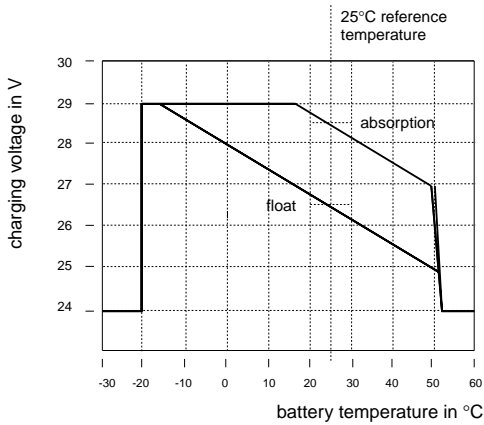

CHARGING CHARACTERISTICS

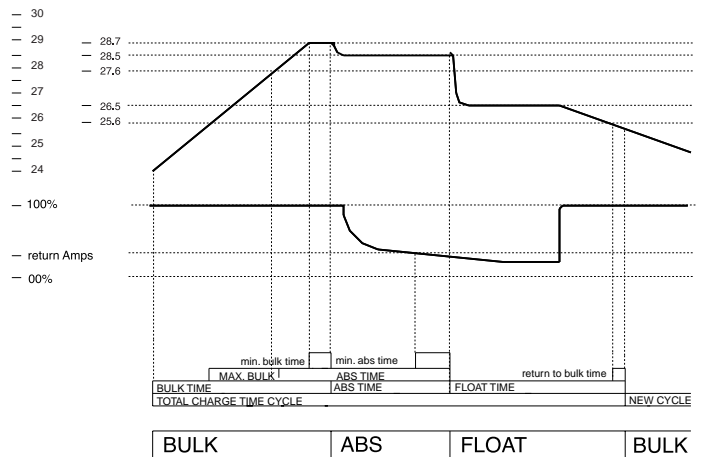

MAX. OUTPUT VERSUS INPUT VOLTAGE

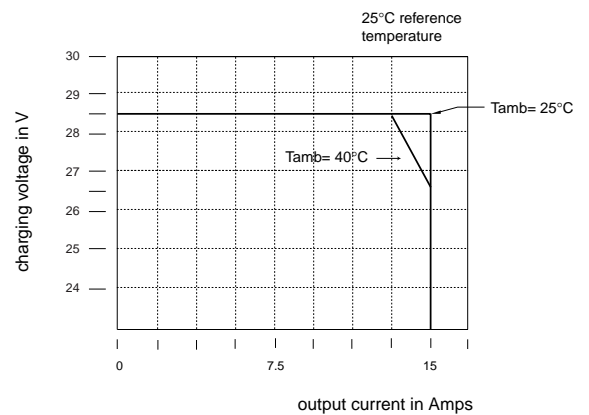
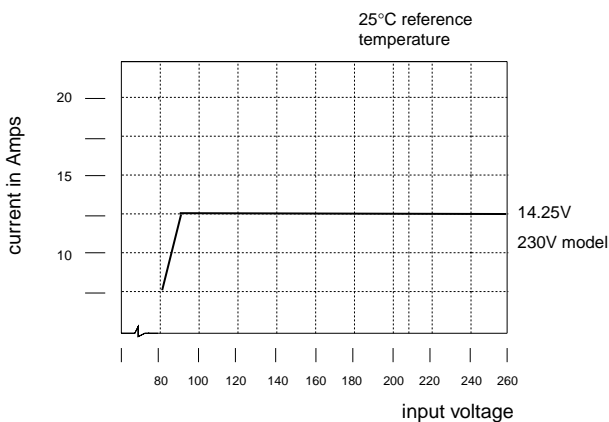

11 DATA SHEETS MASS 24/25-2

MAIN INFORMATION

Design	: by MASTERVOLT
Manufacturer	: ISO 9001 certified
Model / name	: MASS 24/25-2
Product	: battery charger/rectifier
Article no	: 04-00-20250
Colour	: • RAL 5021, wasserblau • RAL 7037, grey
Weight excl. packing	: 2.6 kg
Shipping weight	: 4 kg
Cabinet type	: MASS 1 cabinet
Dimensions	: hxwxd. 325 x 220 x 111 mm
Carton dimensions	: hxwxd. 350 x 250 x 160 mm
Type of packing	: carton recycable
Available	: 230V / 50-60Hz
Availability	: normally from stock, from July '99 onwards



Mass 24/25-2 battery charger/rectifier, art.no 04-00-20250, in new 'high tech' enclosure.

TECHNICAL SPECIFICATIONS

Function apparatus	: charging of 24V lead acid batteries and power simultaneously loads
Nominal input voltage	: 230V AC, 1ph, 3wire, 50/60 Hz
Input voltage range full specs	: 190..250V, 50/60 Hz, \pm 5%
Input voltage range no-defects	: 0..250V, 33-80 Hz
Input current	: at 230V AC: 3.6A
Inrush current	: no inrush current, soft start, according to IEC 1003-3
Power factor	: 1, power factor controlled, IEC 555-2
Max. input power	: 800 Watt
Efficiency	: > 88%
Output voltage	: nominal 24V DC
Output current	: nominal 25 Amps
Charge characteristic	: three-step, fully automatic, IUoUo, programmable
Kind of batteries	: open & sealed lead acid batteries
Charge voltage 25°C	: • bulk voltage 28.7V • absorption 28.5V • wet float 26.5V • gel float 27.6V
Return Amps	: 1.25A
Min. Absorption time	: 15 minutes
Max. Bulk/abs. time	: 6 hours
Return new cycle voltage	: 25.6V, delay 30 seconds
Temperature compensation	: 60 mV/°C, by temperature sensor
Voltage sense	: fully automatic compensation
Ripple voltage	: max. 100mV rms, resistive load, full power
Voltage accuracy	: voltage \pm 2%
Current accuracy	: current \pm 3%
Maximum output	: • 25 Amps at 28.5 Volt at 25°C ambient • 25 Amps at 26.5V at 40°C ambient
DC leakage drain	: < 5 mA
Number of outputs	: one main outputs and one 3 Amps Slave Charger
AC/DC connections	: internal, min. AC cable size: 2.5 mm ² / min. DC cable size: 16 mm ²
Jumper selections	: • gel/wet battery selection • forced to float • battery isolator compensation
Remote indication	: status bulk, absorption, float
Remote connection	: by telephone plug-in jack - RJ45
Temperature connection	: by telephone plug-in jack - RJ45
Smart controls	: QRS232 output by telephone plug - RJ45

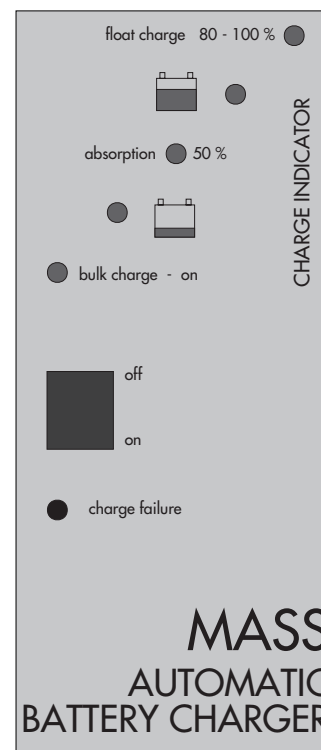

Standard control on unit.

TECHNICAL SPECIFICATIONS

Short circuit protection	: yes, reduced output max. 25 Amps
Reverse polarity protection	: yes, by internal fuses
Over heat	: yes, derating output and shut off by 80°C temperature on heatsink
Storage temperature	: -25°C to 80°C
Operating ambient temperature	: -20°C to 40°C, derating with 2.5% / °C > 40°C
Humidity	: maximum 95%, not condensing
Vibration	: according IEC 68-2-6
Cooling	: mix of conventional and forced air cooling
Forced cooling	: by one variable speed maintenance free DC fan
Environmental protection	: IP23
Reliability/life time	: <ul style="list-style-type: none"> • MTBF 30.000 hours • 1/4 life time period, $U_{in} = 207V$ AC, $U_{out} = 28.5$, $I_{out} = 25$ Amps at $T_{amb} 40^{\circ}C$ • 3/4 life time period, $U_{in} = 207V$ AC, $U_{out} = 26.5$, $I_{out} = 25$ Amps at $T_{amb} 25^{\circ}C$

ELECTRO MAGNETIC COMPATIBILITY

Electro Magnetic Emission	: better than EN 50081-1 (gen. emission standard, scope; residential, commercial & light industry)
Electro Magnetic Immunity	: better than EN 50082-1 (gen. emission standard, scope; residential, commercial & light industry)
Safety	: according to IEC 335-2-29, polarity protected by means of a breaker, short break

WHAT TO DO IN CASE OF A DEFECT?

- ✓ Consult factory in Amsterdam, tel. +31-20-3422100, or your local Repair Center.

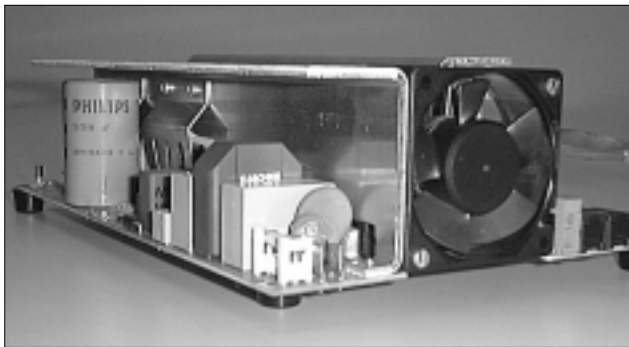

Main PCB of the MASS 24/25-2.

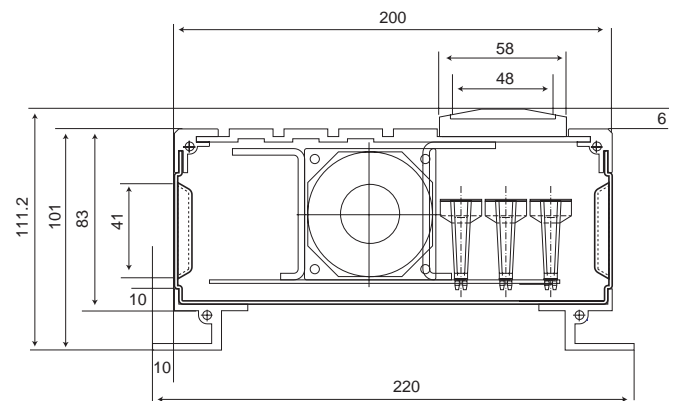

Dimensions of the new cabinet and PCB.

COMPLIANCES

- **CE:**
Is in conformity with the provision of the EC EMC directive 89/336/EEC and amendments 92/31/EEC, 93/68/EEC.
The following harmonized standards have been applied:
 - Generic emission standard : EN 50081-1:1992
 - Generic immunity standard : EN 50082-1:1992
- **LLOYDS, DNV, ABS:**
MASTERVOLT has constructed this product for rugged circumstances in professional or leisure situations.
This product can be type-approved individually. Price approx. US \$ 1500 per certification.
- **MANUFACTURED UNDER ISO 9001.**

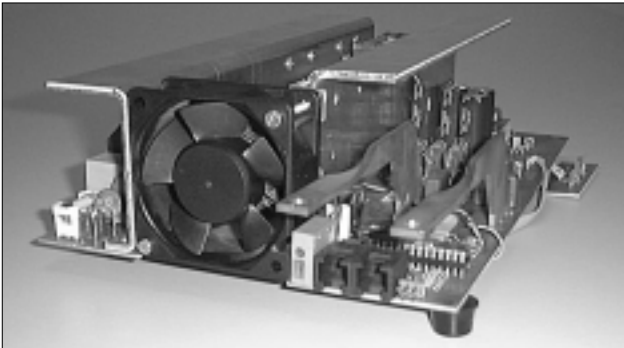

Main PCB of the MASS 24/25-2.

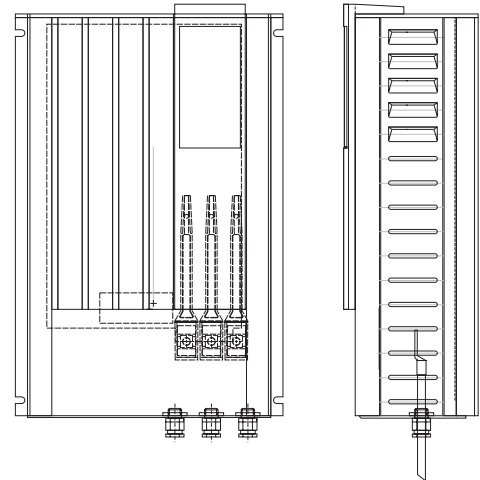

New 'high tech' enclosure.

ACCESSORIES & REMOTES

Article no	description	
04-15-00100	basic remote control	LED's
--	standaard remote contol	LED's current control
--	advanced remote control	display with owner's settings
04-15-00300	MASS 1 temperature sensor	
--	MASS 1 cable set	
--	MASS 1 remote cable set	
00-17-05000	Adjustment Interface	
--	Smart alarm control box	

SERVICE INFORMATION

Article no	description
--	sub assy, main PCB board
--	complete aluminium heatsink
--	cover module
--	connection module
--	front indicator module
--	installation blocks



Adjustment Interface, art. no 02-17-05000.
The below mentioned data can be adjusted with this digital instrument:

- adjustment charge voltage (e.g. traction)
- 'return' Amps etc.

OPERATING PRINCIPLE

Fully automatic power factor switch mode battery charger, suitable as power supply using a separate non-isolated pre regulator boost converter for power factor correction, followed by a double forward converter controlled by a combination of analogue hardware and microprocessor control.

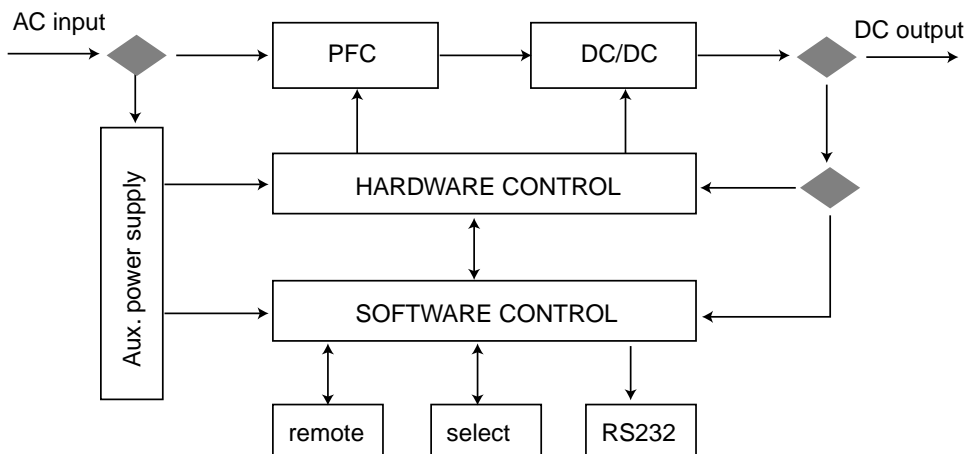

Set points register	Setpoint
1	Min. bulk time 30 sec.
2	Temperature variation 60 mV/C
3	Return to bulk time 30 sec.
4	Return to bulk voltage 25.60 V
5	Max. bulk/abs time 360 min.
6	Min. abs time 15 min.
7	Return Amps 1.25 Amps
8	Max. charge current 25 Amps
9	Bulk voltage 28.70 V
10	Abs voltage 28.50 V
11	Float voltage 26.50 V
12	Forced to float voltage 26.50 V
13	Gel voltage setting 1.10 V
14	Diode compensation setting 600 mV
15	DC high alarm on 30 V
16	DC high alarm off 29 V
17	DC low alarm on 20 V
18	DC low alarm off 22 V
19	Alarm delay time 30 sec.

- Temperature variation 5.0 mV/°C per cell
- Reference voltage 25°C
- Battery charging is not allowed above +50°C and under -20°C
- 12 Volt 30 mV/°C
- 24 Volt 60 mV/°C

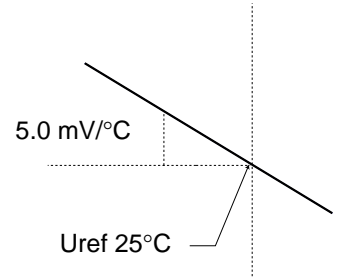

forced float
gell/wet battery
diode compensation

- standard IUU characteristic
- IUU char. increased with 0.6V
- IUU char. high float level
- IUU char. high float, increased with 0.6V
- IU char. low float level
- IU char. low float, increased with 0.6V
- IU char. high float level
- IU char. high float, increased with 0.6V

TEMPERATURE COMPENSATED CHARGING

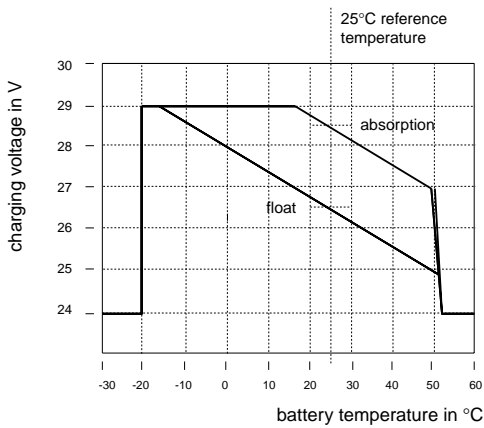

CHARGING CHARACTERISTICS

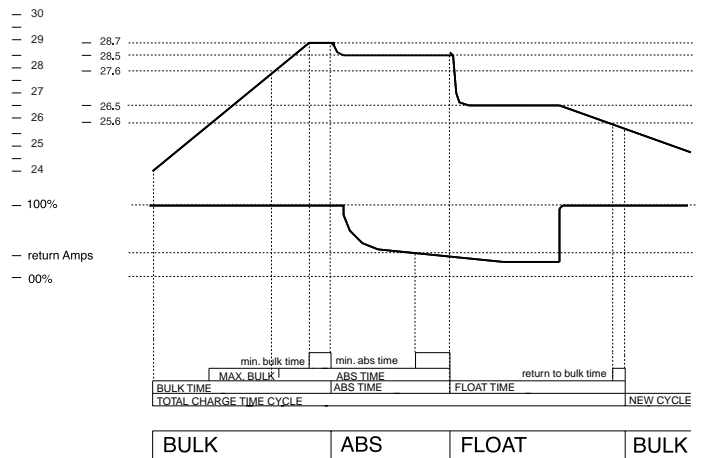

MAX. OUTPUT VERSUS INPUT VOLTAGE

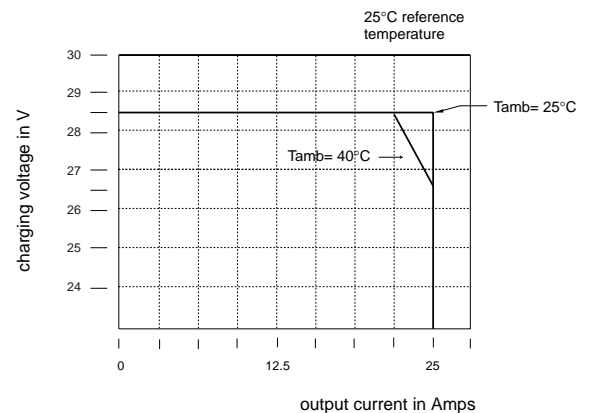
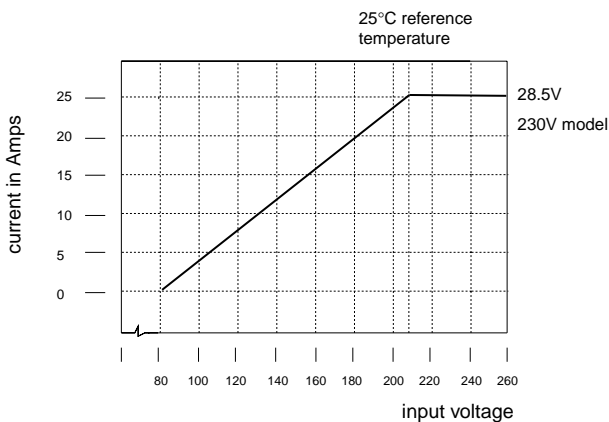

panel code	C-3-RS
part number	07-04-03040

MASTERVISION MODULAR SWITCHBOARDS

CAUTION



- Lethal voltages exist on your vessel. Make sure all shore power, onboard generating sources and batteries are disconnected before beginning installation of your electrical panel.
- AC modules will have lethal voltages on the bus bars and terminals. The coating on these bars is for identification only and should not be relied on as an insulator. Additional safety enclosures may be required in some installations.
- Make sure all AC modules are bonded to the ship's AC ground bus. When grouping modules together to form your panel, a single ground may be used. Use a resistance meter to verify ground to all modules.

SPECIFICATIONS

description: type:	remote standard charger control for Mass & IVO smart chargers
dimensions panel (wxh): panel depth:	120 x 65 mm 40 mm

The standard remote panel

The standard remote panel is a useful power device for remote control of the Mass an IVO smart Mastervolt battery chargers. The standard remote control does indicate the status of the charge control by six high power leds and control the output current by setting the potential meter. The remote control is easy to install by a plug-in standard twisted six pole RJ45 telephone plug between the digital rs232 output of the charger and the panel. The serial communication of the remote control and the charger is based on rs232 technology. The remote panel can be used as an interface for a custom made panel or for a dual remote indicator. The standard remote panel has a CSI (csi=charger status interface) and a DC high/low alarm. The two potential free change-over contacts indicate if the charger is ON or in general failure. The DC alarm set points can be adjusted in the charger by use of the adjustment interface.

Specifications

Remote cable:	
Connector	RJ45, 6 pole, male
Max length	6 meter, max
Type	twisted wire
External led drive:	
I _{max}	5 mA
U _{max}	2,5V
External current control	
R pot cc	0..1kOhm 0..100%
General CSI alarm	
Max rating	1 Amp, 30 VDC
NC-on	When the charger is off or the charger is in failure, the normally closed contact is closed
C	Common
NO-on	When the charger is on and no-failure is indicated the normally open contact is closed
DC-high/low alarm (combined function with CSI)	
Max rating	1 Amp, 30 VDC
NC-on	When there is no DC failure, the normally closed contact is closed
C	Common
NO-on	When there is a DC failure the normally open contact is closed
Connectors	0,75 mm ²

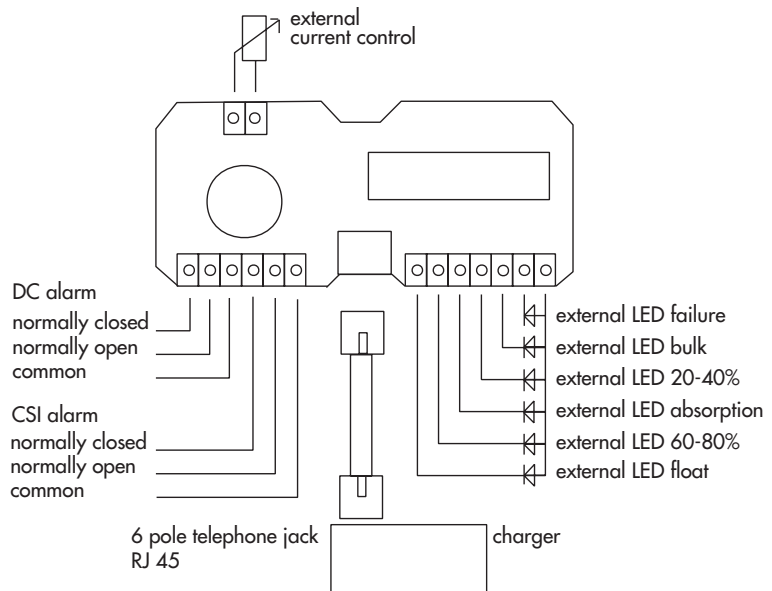
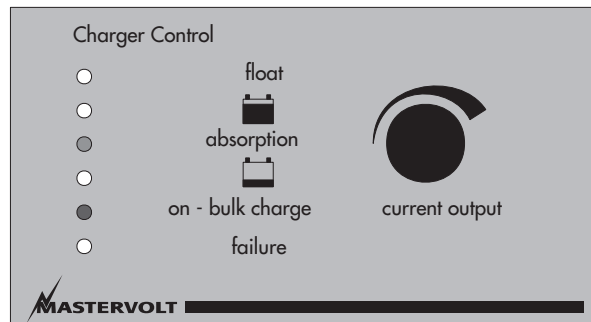

CSI failure

Bat TC failure
Voltage sense failure
Sys. temp. failure
Short break indicator

Battery temperature sensor out of range <20 C & >60 C
Voltage sense out of range >3 VDC
Charger is out of temperature range "overload" (>75--85 C)
Charger in reduced current mode (short break mode)
U_{out} <4..5VDC

DC alarm

Battery range out of range (with standard setting of charger)

	12V	24V	
DC low on	10.0	20.0	VDC
DC low off	11.0	22.0	VDC
DC high on	16.0	32.0	VDC
DC high off	15.0	30.0	VDC
Delay time	30	30	SEC

panel code	C-4-RB
part number	07-04-04100

MASTERVISION MODULAR SWITCHBOARDS

CAUTION



1. Lethal voltages exist on your vessel. Make sure all shore power, onboard generating sources and batteries are disconnected before beginning installation of your electrical panel.



2. AC modules will have lethal voltages on the bus bars and terminals. The coating on these bars is for identification only and should not be relied on as an insulator. Additional safety enclosures may be required in some installations.

3. Make sure all AC modules are bonded to the ship's AC ground bus. When grouping modules together to form your panel, a single ground may be used. Use a resistance meter to verify ground to all modules.

SPECIFICATIONS

description:
type:

remote basic charger control
for Mass & IVO smart chargers

dimensions panel (wxh):
panel depth:

60 x 65 mm
40 mm

The basic remote panel

The basic remote panel is a useful power device for remote control of the Mass an Ivo smart Mastervolt battery chargers. The basic remote control does indicate the status of the charge control by six high power leds.

The remote control is easy to install by a plug-in standard twisted six pole RJ45 telephone plug between the analog output of the charger and the panel. The communication of the remote control and charger is based on analog technology. The remote panel can be used as an interface for a custom made panel or for a dual remote indicator.

The basic remote panel has a combined CSI-DC/alarm (csi=charger status interface).

The potential free change-over contacts indicate if the charger is ON or in general failure. The DC alarm set points can be adjusted in the chargers by use of the adjustment interface.

Specifications

Remote cable:

Connector RJ45, 6 pole, male
Max length 6 meter, max
Type twisted wire

External led drive:

I_{max} 5 mA
U_{max} 2,5V

General CSI alarm

Max rating 1 Amp, 30 VDC
NC-on When the charger is off or the charger is in failure, the normally closed contact is closed
C Common
NO-on When the charger is on and no-failure is indicated the normally open contact is closed
Connectors 0,75 mm²

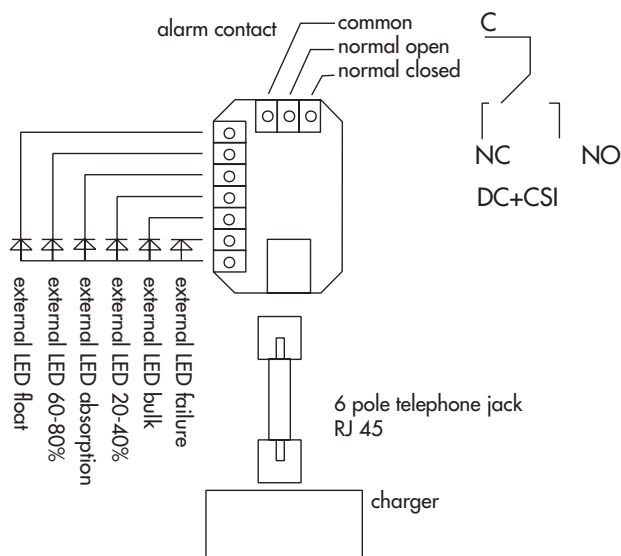
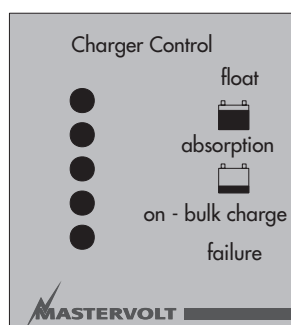

Combined CSI failure and DC high/low alarm

Bat TC failure	Battery temperature sensor out of range <20°C & >60°C °
Voltage sense failure	Voltage sense out of range >3 VDC
Sys. temp. failure	Charger is out of temperature range (overload) (>75--85 °C)
Short break indicator	Charger in reduced current mode (short break mode) U _{out} <4..5VDC

DC alarm

Battery range out of range (with standard setting of charger)

These products fully comply to the latest CE norms in force from Januari 1st 1996 and are produced to ISO 9001 standards.

ISO 9001



	12V	24V	
DC low on	10.0	20.0	VDC
DC low off	11.0	22.0	VDC
DC high on	16.0	32.0	VDC
DC high off	15.0	30.0	VDC
Delay time	30	30	SEC

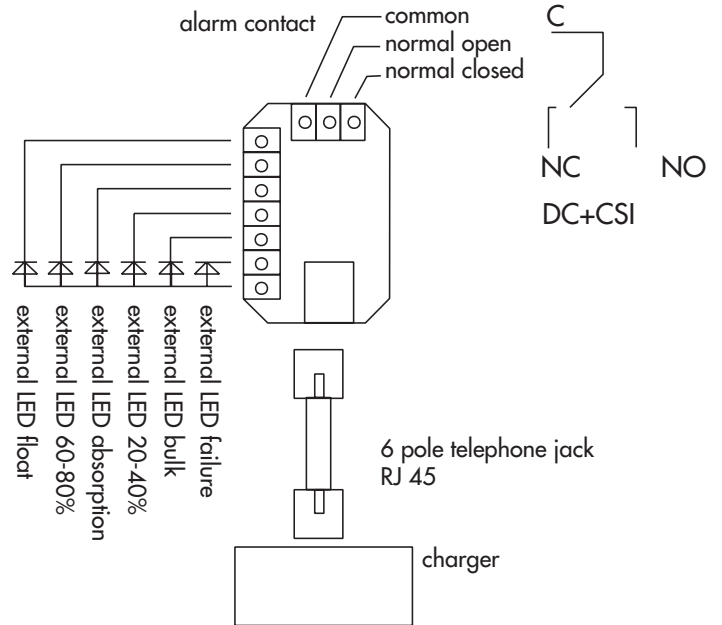
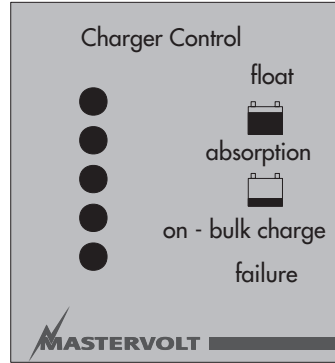
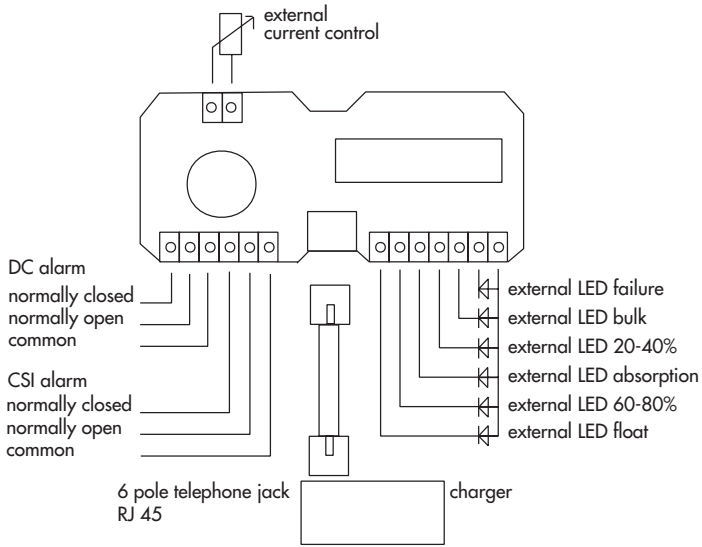
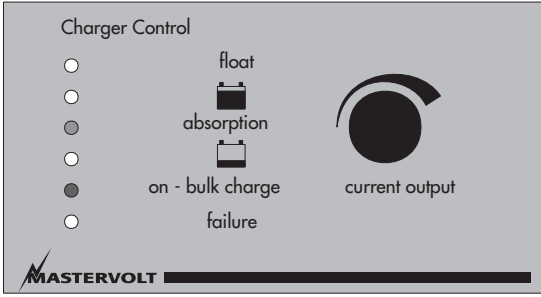

MASTERVOLT

Snijdersbergweg 93, 1105 AN Amsterdam, The Netherlands

Tel.: +31-20-3422100

Fax: +31-20-6971006