



Installation and Maintenance Instructions

Pre plumbed cylinder

CS5800iAW 180 MCP, CS5800iAW 210 MP and CS5800iAW 250 MP

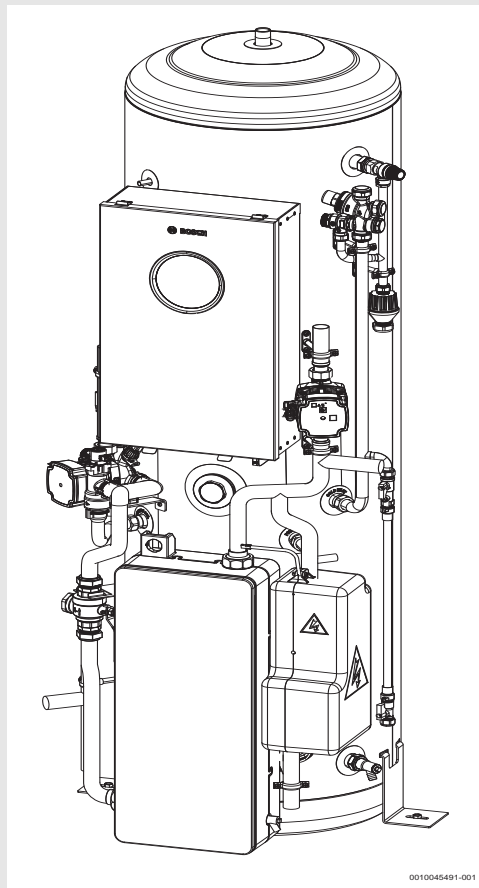

Table of contents

1	Explanation of symbols and safety instructions	3
1.1	Explanation of symbols	3
1.2	General safety instructions	3
2	Regulations	3
3	Product Information	4
3.1	Scope of delivery	4
3.1.1	Scope of delivery	4
3.1.2	180 SL Dimensions and minimum clearances	4
3.1.3	210L and 250L Dimensions and minimum clearances	6
3.1.4	180 SL connections	7
3.1.5	210L and 250L connections	8
3.1.6	Product overview 180 SL	9
3.2	Product identification	11
3.2.1	Declaration of Conformity	11
3.3	Standard accessories	11
3.3.1	Required system components	11
3.3.2	Optional accessories	11
4	Pre-Installation	11
4.1	Placement of the indoor unit	11
4.2	Mains supply	12
4.2.1	Electrical supply	12
4.2.2	Explanations for the hydraulic configuration	12
4.3	Water quality	12
4.3.1	Quality requirements for the heating water	12
4.3.2	Water quality for potable water (DHW)	13
4.4	Minimum volume and execution of the heating system	14
4.5	Check size of expansion vessel (central heating side)	14
4.6	Pressure relief pipework	14
4.7	Discharge Arrangement (DHW)	15
4.8	Cleaning primary systems	16
4.8.1	Flushing the system	16
5	Installation	17
5.1	Transport and storage	17
5.2	Moving the appliance to the installation place	17
5.3	Fastening the cylinder to the ground	18
5.4	Installation checklist	18
5.5	Installation of accessories	18
5.5.1	Safety thermostat	19
5.6	Remove covers	19
6	Hydraulic connections	19
6.1	Insulation	19
6.2	Pipe connections, general	19
6.3	Connect the indoor unit to the heat pump	21
6.4	Connect the indoor unit to the heating system	22
6.5	Connect the indoor unit to the mains water supply	22
6.6	Heat pump, indoor unit and heating system filling	23
7	Electrical connection	24
7.1	Safety instructions	24

7.2	Cable types	24
7.3	Cable routing	24
7.3.1	Power cables	24
7.3.2	Control and sensor cables	24
7.4	Access to control box	25
7.5	Replacing/connecting the power cables	26
7.5.1	Removal/replacement of 230V supply cables	27
7.5.2	Connection of 230V supplies at the XCU-SEH unit	27
7.5.3	Connection of 230V accessories at the XCU-SEH unit	27
7.5.4	Overview of connectors in the XCU-SEH area	28
7.6	Connection of control and sensor cables	29
7.6.1	Installation/replacement of low voltage cables	29
7.6.2	CAN-BUS	29
7.6.3	Installation of the temperature sensor	30
7.6.4	Outdoor temperature sensor T1	30
7.6.5	Flow temperature sensor TO	30
7.6.6	External connections in XCU-THH area for control & sensor cables	30
7.7	Replace cover and final checks	31
8	Commissioning	31
8.1	Commissioning checklist	31
8.2	Commissioning of the control panel	31
8.3	Heat pump, indoor unit and heating system ventilation	32
8.4	Operating temperatures	33
8.5	Function test	33
8.5.1	Overheating protection (OHP)	33
8.6	Finishing commissioning	33
8.6.1	Appliance/product guarantee	33
9	Inspection and maintenance	34
9.1	Particle and magnetite filter	34
9.2	DHW expansion vessel & PRVs	34
9.3	Draining of appliance	35
9.4	Shut down the heating system	35
10	Troubleshooting	35
10.1	Operating and fault displays	35
11	Environmental protection and disposal	35
12	Data Protection Notice	35
13	Technical Specifications/Logs	36
13.1	Technical specifications	36
13.2	Wiring diagram	37
13.2.1	Wiring diagram of appliance	37
13.2.2	Cable plan	38
13.2.3	Measurements from temperature sensors	38
13.3	Hydraulic configuration	38
13.3.1	Heating circuit without mixer	39
13.3.2	Explanation of symbols	41
13.3.3	Performance charts for circulation pumps	42
14	Benchmark Commissioning	43

1 Explanation of symbols and safety instructions

1.1 Explanation of symbols

Warnings

In warnings, signal words at the beginning of a warning are used to indicate the type and seriousness of the ensuing risk if measures for minimizing danger are not taken.

The following signal words are defined and can be used in this document:

 **DANGER**
DANGER indicates that severe or life-threatening personal injury will occur.

 **WARNING**
WARNING indicates that severe to life-threatening personal injury may occur.

 **CAUTION**
CAUTION indicates that minor to medium personal injury may occur.

NOTICE
NOTICE indicates that material damage may occur.

Important information

 **i**
The info symbol indicates important information where there is no risk to people or property.

Additional symbols

Symbol	Meaning
▶	a step in an action sequence
→	a reference to a related part in the document
•	a list entry
–	a list entry (second level)

Table 1

1.2 General safety instructions

Notices for the target group

These installation instructions are intended for gas, plumbing, heating and electrical contractors. All instructions must be observed. Failure to comply with instructions may result in material damage and personal injury, including danger to life.

- ▶ Read the installation, service and commissioning instructions (heat source, heating controller, pumps, etc.) before installation.
- ▶ Observe the safety instructions and warnings.
- ▶ Follow national and regional regulations, technical regulations and guidelines.
- ▶ Record all work carried out.

Intended use

This product is intended for use in sealed heating systems in residential buildings.

Any other use is considered as not intended. Liability will not be assumed for any resulting damage.

Installation, commissioning and service

The product may only be installed, brought into operation and maintained by trained personnel.

- ▶ Use only original spare parts.

Electrical work

Electrical work must only be carried out by a competent person in relation to the electrical safety requirements of the relevant UK regulations.

- ▶ Before starting electrical work;
 - Ensure that the electricity supply is safely isolated and secured to prevent inadvertent re-connection. Information on safe isolation can be found in the Health and Safety Executive guidance HSG85.
 - Using test equipment approved to GS38 to confirm that the electricity supply is disconnected.
 - Before touching live parts: Wait at least five minutes to discharge the capacitors.
- ▶ Refer to the manufacturer's information when installing non Worcester components and systems to the Worcester appliance.

Connection to supply mains

- ▶ There are two mains supply cables to this product
- ▶ Means to safely disconnect the unit from supply mains must be incorporated.

Connection to the water supply (cold main)

This unit is designed to be permanently connected to the water supply. The connection must not be established with a hose set.

The maximum inlet pressure of the water is 10 bar (relative pressure).

The minimum permissible inlet pressure of the water is 1,5 bar.

Handover to the user

When handing over, instruct the user how to operate the heating system and inform the user about its operating conditions.

- ▶ Explain how to operate the heating system and draw the user's attention to any safety relevant action.
- ▶ In particular, point out the following:
 - Modifications and repairs must only be carried out by an approved contractor.
 - Safe and environmentally compatible operation requires inspection at least once a year and proper cleaning and maintenance.
- ▶ Point out the possible consequences (personal injury, including danger to life or material damage) of non-existent or improper inspection, cleaning and maintenance.
- ▶ Leave the installation instructions and the operating instructions with the user for safekeeping.

2 Regulations

Installation

The pre-plumbed cylinder is specifically designed to be installed in conjunction with an air source heat pump.

Unvented cylinders are a controlled service as defined in the latest edition of the building regulations and should only be carried by a competent qualified installer.

The relevant regulations are:

England and Wales - Building Regulation Part G Section G3

Scotland - Technical Standard Section 4

Northern Ireland - Building Regulations Part F

After installation the Benchmark log book and included commissioning sheets must be completed and left along with these instructions with the householder for future reference.

Any water distribution and central heating installation must comply with the relevant recommendations of the current version of Regulations and British Standards listed below:

Building Regulations

IEE Requirements for Electrical Installations (BS 7671)

Water Regulations

Manual Handling Operations Regulations.

British Standards

Where no specific instruction is given, reference should be made to the relevant British Standard codes of Practice.

- BS7074:1
 - Code of practice for domestic and hot water supply
- BS7593
 - Treatment of water in domestic hot water central heating systems
- BS6798
- BS5449
- BS5540:1
- BS5540:2
- CP331:3
- BS8558
- BS7671
 - IET Wiring Regulations

Health and Safety Document No. 635

3 Product Information

3.1 Scope of delivery

3.1.1 Scope of delivery

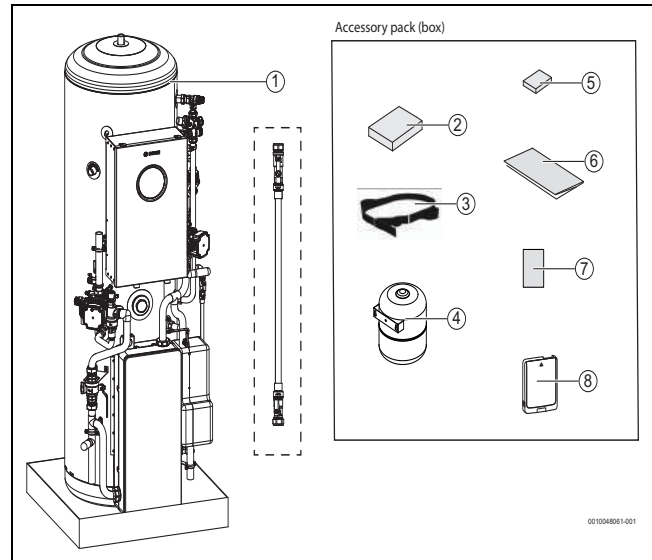

Fig. 1 Standard delivery

1. Indoor unit with pre-assembled filling link* (dotted outlined enlargement)

Accessory pack

2. Hardware pack
3. Strap to lift the cylinder
4. Expansion vessel for domestic water 18L
5. Outdoor temperature sensor
6. Documentation
7. ErP label
8. Connect-Key K30

*The filling link is used only for installation and re pressuring, store the braided hose close to indoor unit after system filling

Model Name	Cylinder Size/ Description
CS5800iAW 180 MCP	180 Litre Slim line (180 SL)
CS5800iAW 210 MP	210 litre (210 L)
CS5800iAW 250 MP	250 litre (250 L)

Table 2 Model name, description

3.1.2 180 SL Dimensions and minimum clearances

- The following details cover the installation, service and maintenance clearances for the product.



Note the dimensions and minimum clearances in the figures for all three directions carefully. Note also the position of the door if installed in a cupboard.

CAUTION

Risk of damage to product or property

The product will overheat if the clearance space around the product is restricted by objects.

- ▶ Do not restrict this space with the addition of cupboards, shelves etc. next to or around the product.
- ▶ This product contains electrical components, do not store any combustible materials on or next to the product, such as clothes, towels, paper or plastic bags.

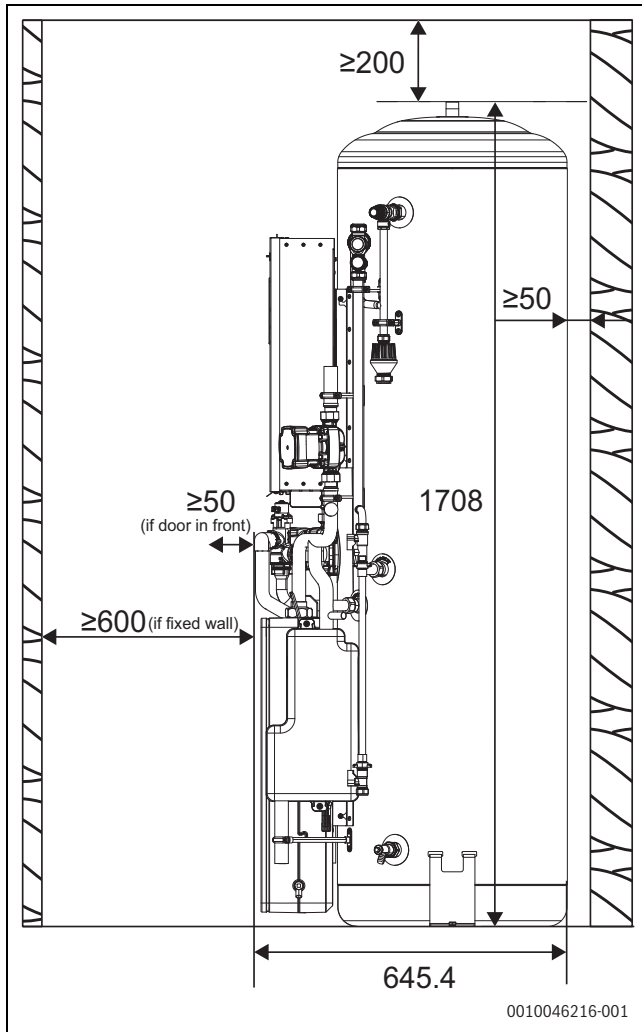

Fig. 2 Cylinder depth and height specifications (mm) and front, rear and height clearances limitation (180 Litre Slim line)

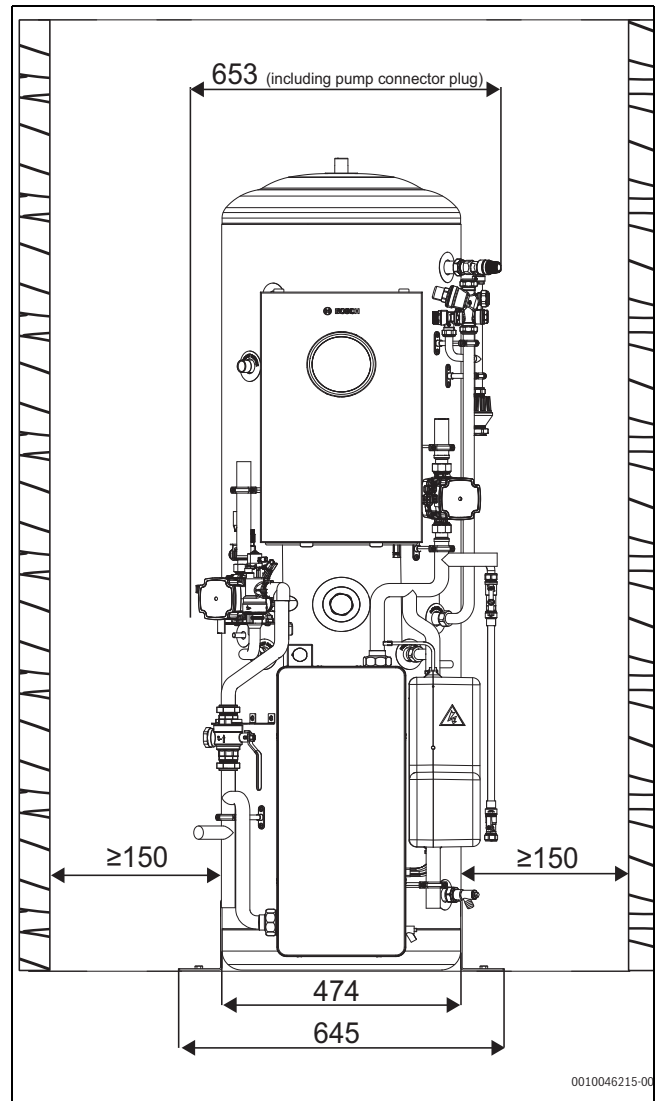

Fig. 3 Cylinder width specifications (mm) and lateral clearances limitation (180 Litre Slim line)

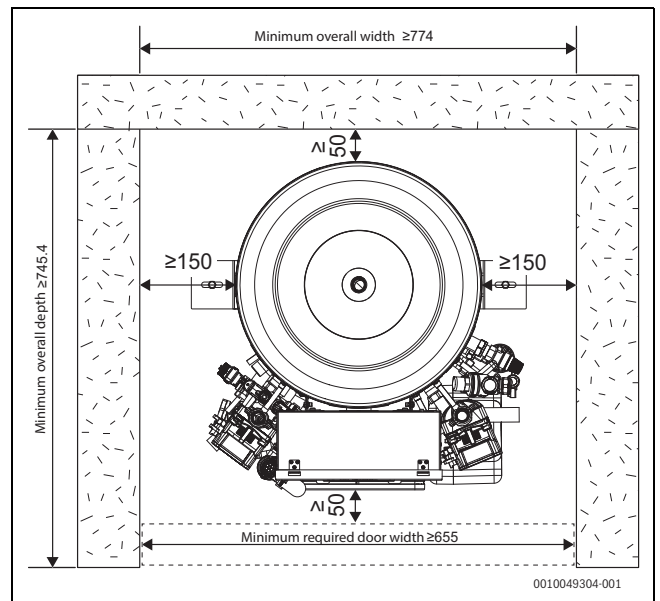

Fig. 4 Lateral clearance limitation and door frame minimum width when installing in a cupboard with front door (180 Litre Slim line)

3.1.3 210L and 250L Dimensions and minimum clearances

- The following details cover the installation, service and maintenance clearances for the product.



Note the dimensions and minimum clearances in the figures for all three directions carefully. Note also the position of the door if installed in a cupboard.



CAUTION

Risk of damage to product or property

The product will overheat if the clearance space around the product is restricted by objects.

- Do not restrict this space with the addition of cupboards, shelves etc. next to or around the product.
- This products contains electrical components, do not store any combustible materials on or next to the product, such as clothes, towels, paper or plastic bags.

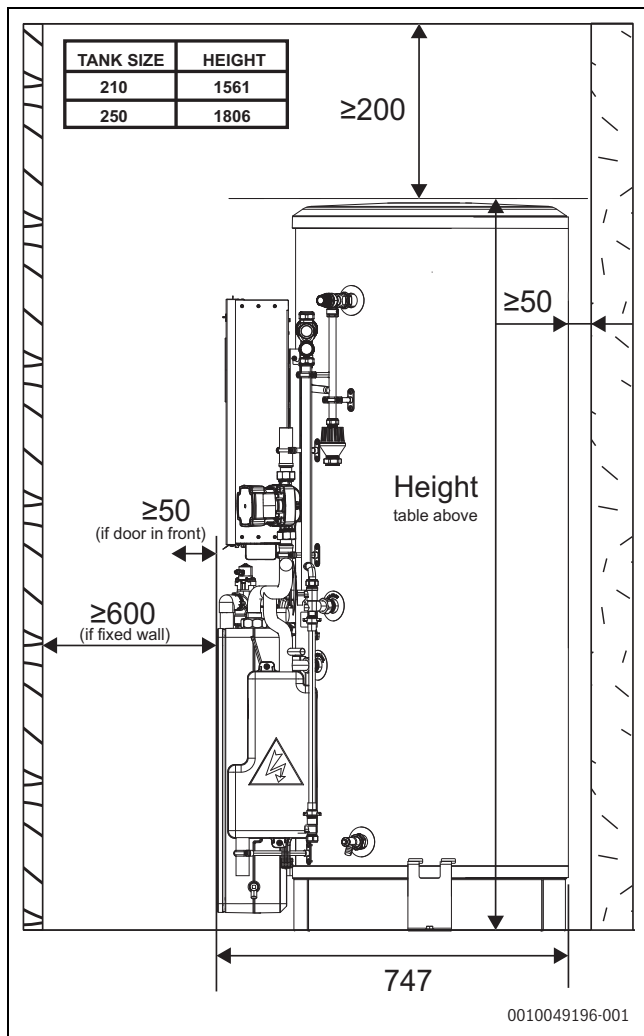

Fig. 5 Cylinder depth and height specifications (mm) and front, rear and height clearances limitation (210 litre base drawing - note height differences to 250 litre)

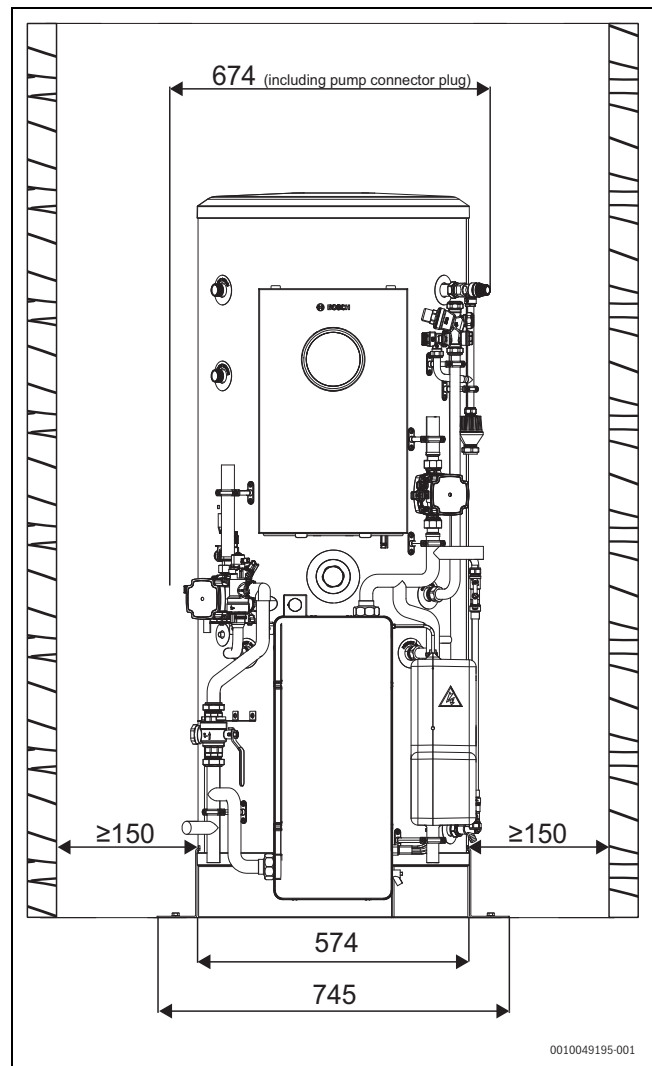

Fig. 6 Cylinder width specifications (mm) and lateral clearances limitation (both 210 and 250 litre, 210 litre base drawing)

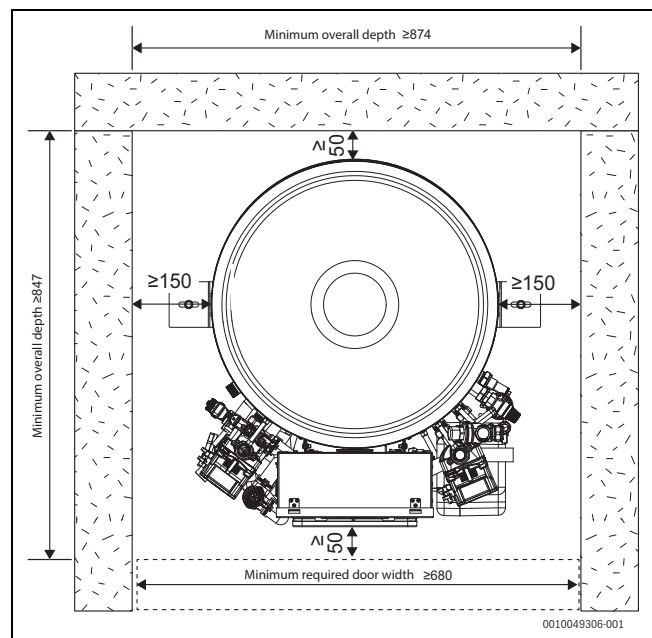

Fig. 7 Lateral clearance limitation and door frame minimum width when installing in a cupboard with front door (both 210 and 250 litre)

3.1.4 180 SL connections

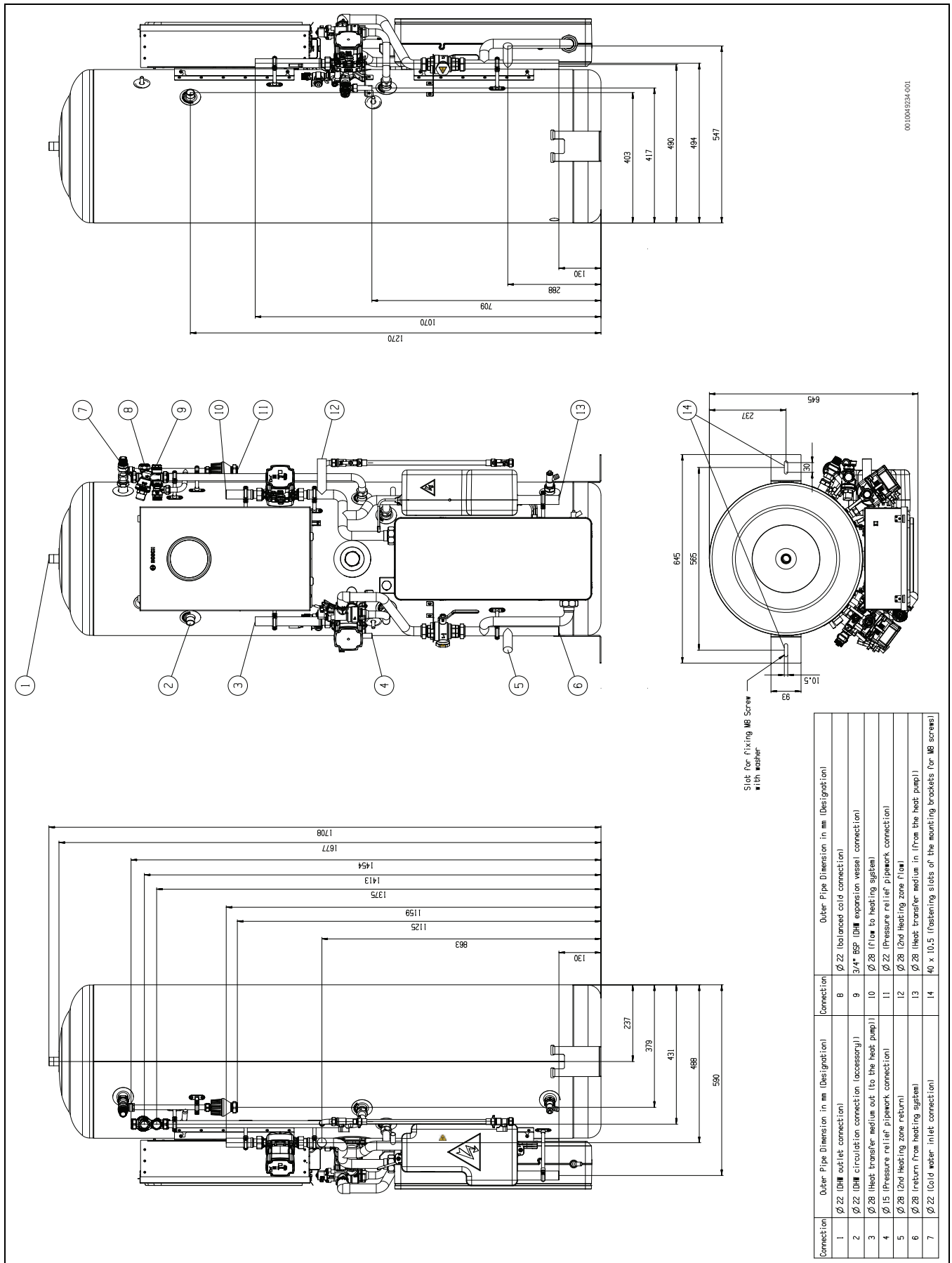

Fig. 8 Connections dimensions for the 180sl cylinder

3.1.5 210L and 250L connections

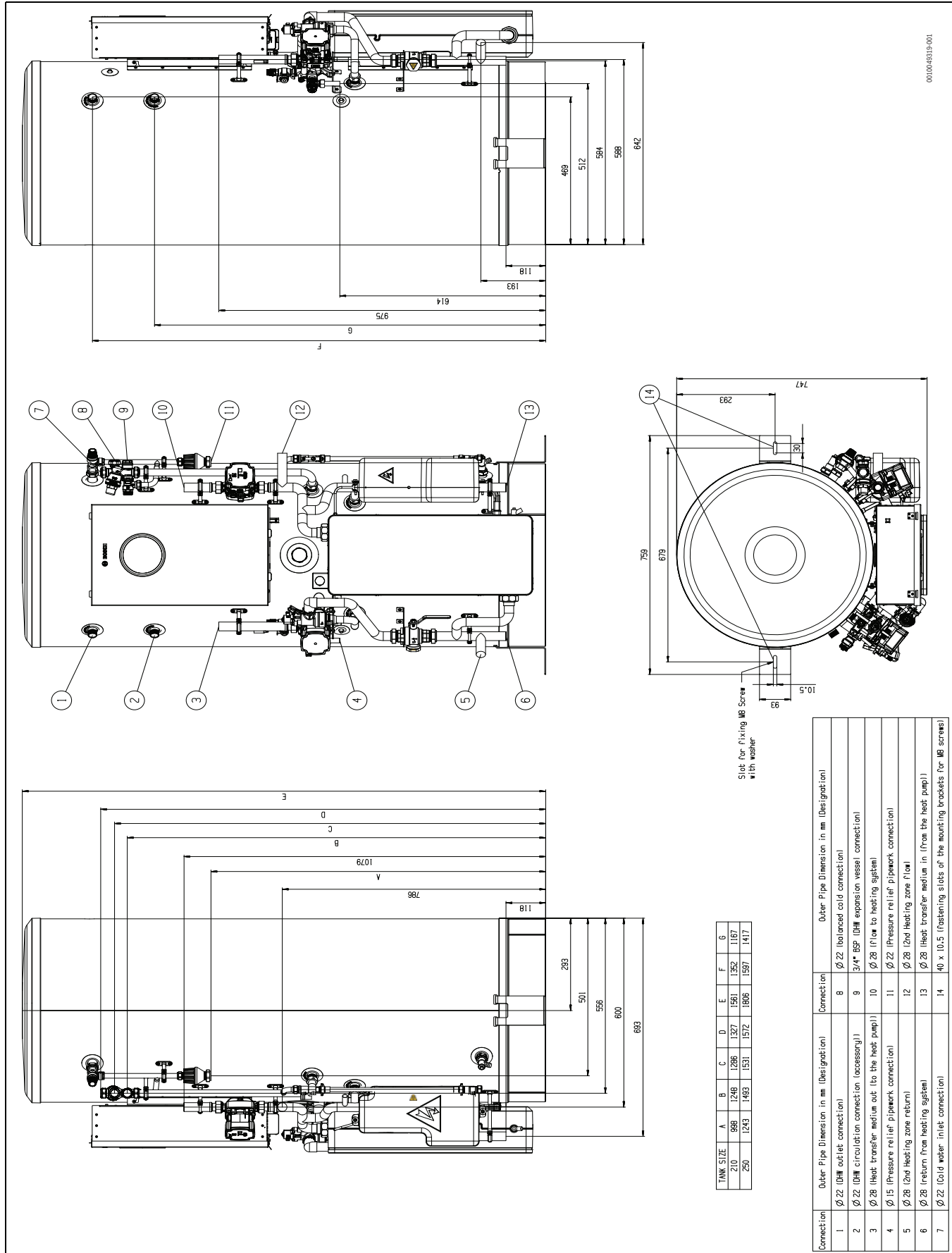

Fig. 9 Connections dimensions for 210l and 250l cylinder

3.1.6 Product overview 180 SL

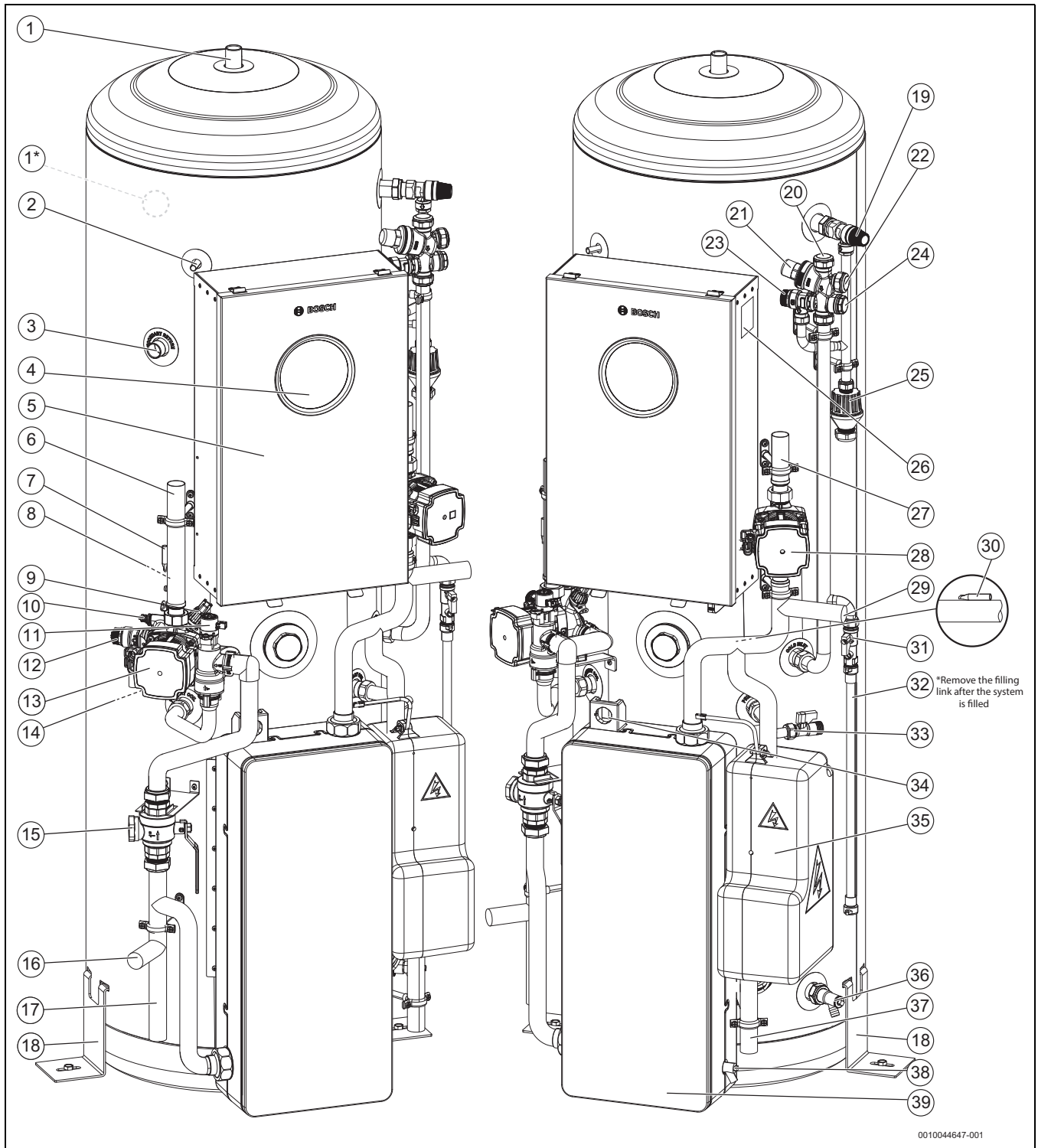

Fig. 10 Left and right view of 180 litre Pre-Plumbed Cylinder

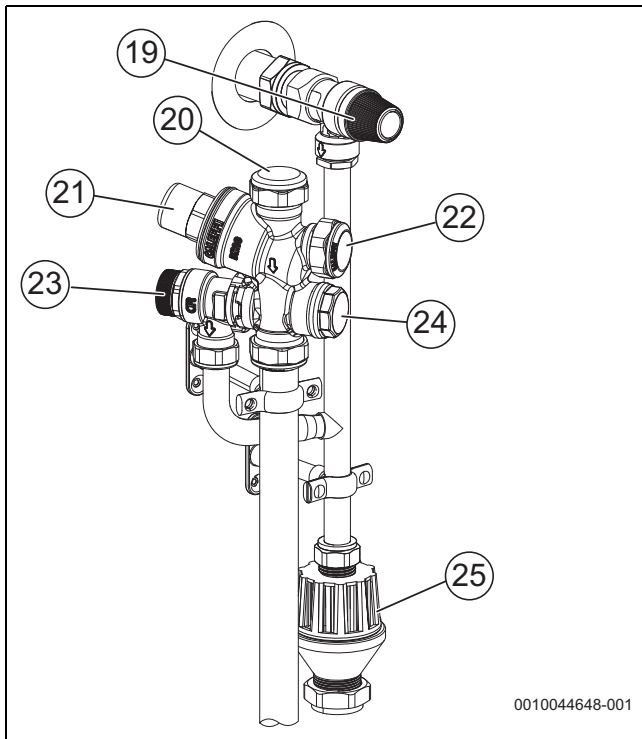

Fig. 11 Enlarged view right-hand component cluster

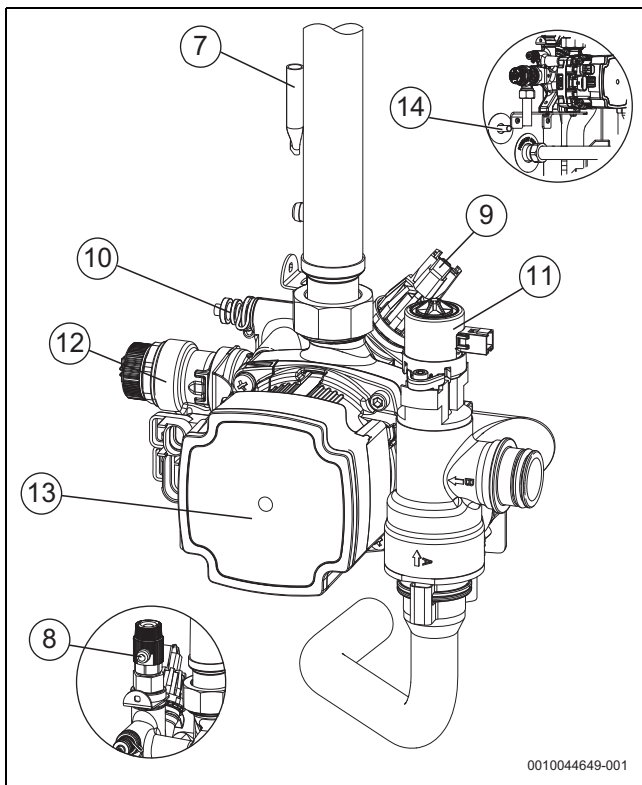

Fig. 12 Enlarged view of left component cluster

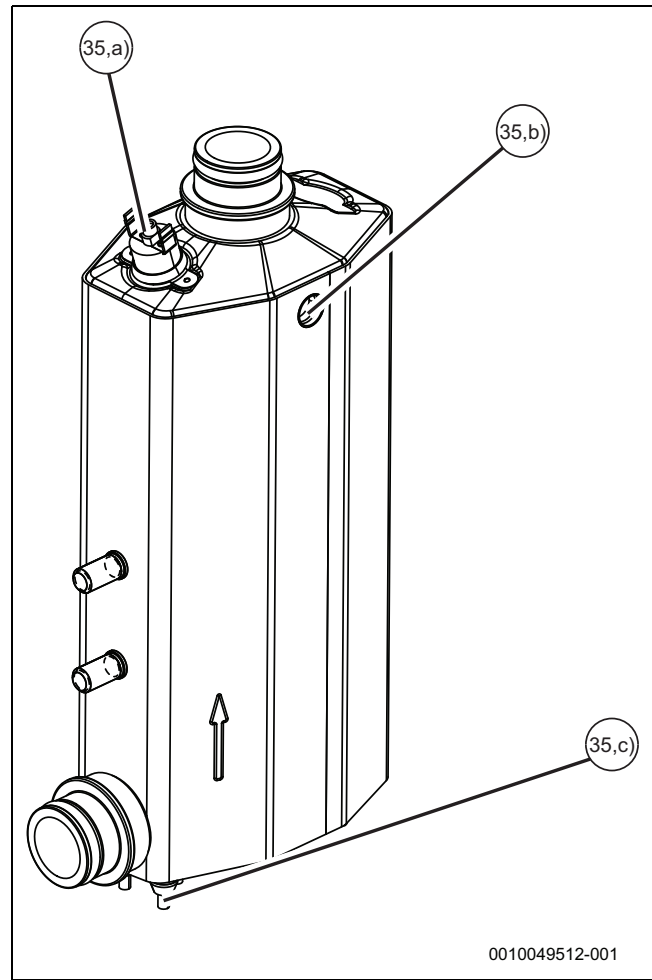

Fig. 13 Enlarged view of e-heater with covers removed

1. DHW (Domestic Hot Water) outlet connection
– (1* equivalent DHW outlet connection position on the 210 and 250 litre versions of the Pre-Plumbed Cylinder)
2. Temperature sensor DHW top (TW2)
3. DHW circulation connection (optional)
4. Control unit UI800 CS
5. Control box
6. Heat transfer medium out (return to the heat pump)
7. Temperature sensor return temperature to heat pump TCO
8. Manual purge vent (behind the pipe)
9. Pressure sensor heating circuit JCO
10. Pressure gauge connection
11. Diverter valve
12. PRV (Pressure Relief Valve) heating circuit, 3 bar
13. Heat carrier pump PCO
14. Temperature sensor DHW bottom (TW1), behind the pump
15. Particle filter (filter with magnet)
16. 2nd Heating zone return (optional)
17. Return from the heating system
18. Mounting bracket
19. TPRV (Temperature & Pressure Relief Valve) DHW, 10 bar/90°C
20. Cold water inlet - inlet safety group
21. Pressure reducing valve, 3.5 bar - inlet safety group
22. Balanced cold feed - Inlet safety group
23. PRV (Pressure Relief Valve) DCW (Domestic Cold Water), 6 bar - Inlet safety group
24. DHW expansion vessel connection - Inlet safety group
25. Tundish
26. Data plate

27. Flow to heating system
28. Circulation pump heating circuit PC1
29. 2nd Heating zone flow (optional)
30. Flow temperature sensor heating circuit T0
31. Double check valve with isolation valve, gauge port and pre-mounted blanking cap
32. External filling link (braided metal hose with wing nuts) (*Remove after the system is filled)
33. Isolation valve with pre-mounted blanking cap
34. Pressure gauge
35. Electrical heater 3kw (covered)
 - 35a) Temperature safety switch for electrical heater - cable entry at the front of the heater
 - 35b) Temperature sensor flow primary flow from heat pump-Tc1- cable entry at rear of the heater
 - 35c) Power supply cable entry at the rear of the heater
36. Drain valve (cylinder)
37. Heat transfer medium in (from heat pump)
38. Drain Valve CH (Central Heating) system
39. Buffer vessel



3.2 Product identification

Data plate

The data plate contains performance data, approval data and the serial number of the product.

The position of the data plate can be found in the product overview in this chapter.

The G3 relevant symbols mean the following

  Maximum pressure for space heating (bar)

 Volume of domestic hot water cylinder (L)

3.2.1 Declaration of Conformity

The design and operating characteristics of this product comply with the British, European and supplementary national requirements.



The UKCA and CE markings declare that the product complies with all the applicable British and European legislation, which is stipulated by attaching these markings.

You can request the complete text of the Declaration of Conformity from the UK address indicated in this document.

3.3 Standard accessories

3.3.1 Required system components

The following components are not included in the standard delivery but are required for the initial startup and operation of the system.

Heating system:

- Automatic air vent valve [VL1]
- Expansion vessel

Hot tap water:

- Thermostatic valve hot water

Heat pump:

- Manual valve [VC4] between the indoor unit and the heat pump. The valve is used when filling and venting the system. It is not allowed to completely disconnect the heat pump from the indoor unit, therefore only one valve is required.

3.3.2 Optional accessories

The following accessories can be added on and are not required for operation of the system.

- Room controller
- Magnetite separator (system filter)
- Thermostatic valve hot water (required for DHW temperatures above 65 °C)
- DHW circulation pump
- Safety thermostat for under floor heating
- Non-return valve for the heating system

A non-return valve may be necessary to prevent self-circulation in the heating system. This can mainly arise in the following situations:

- Heating system with radiators
- The indoor unit is installed below the heating system (basement or multi-story building)
- The outdoor unit is installed on the same height or below the indoor unit

4 Pre-Installation

NOTICE

Risk of damage to system or product!

Before installation

- ▶ All the following Pre-Installation sections must be read and requirements met before starting product or ancillary equipment installations.
- ▶ Run the connector pipes for the heating system and cold water/DHW in the building up to the installation location of the indoor unit.
- ▶ This product is only suitable for installing internally within a property at a suitable location onto a flat, fixed rigid surface at least the same size as the product and capable of supporting the product weight.
- ▶ Product must be fixed to the floor using supplied mounting brackets.
- ▶ The system must be sealed and not open vented.

4.1 Placement of the indoor unit

- The indoor unit is placed in the building. The pipework between the heat pump and indoor unit must be as short as possible. Use insulated pipes.
- The maximum pipe length between the heat pump and the indoor unit depends on the heat pump size as well as on the pipe diameter see section 6.2
- The ambient temperature around the indoor unit shall be between +10 °C and +35 °C.
- The unit must not be installed in a bathroom/wet room or outdoors



No surface protection is required against heat transfer from the product.

4.2 Mains supply

4.2.1 Electrical supply

- There must be two electrical supplies to the appliance: control unit and heater. It must be possible to isolate each supply.
- Supply: 230V AC - 50 Hz (each)
- This product must **not** be connected to a three phase supply.
- The wiring between the product and the electrical supply must comply with the latest IET wiring regulations that apply to wiring to Class 1 fixed equipment.
- The appliance incorporates low energy DC modulating pumps. If an RCD is required, it must be minimum type A. Type AC must not be used. This applies only to the control unit (not the heater).
- The product must be earthed.
- Cable 1 (control unit): Heat resistant PVC 3-core flexible cable 1.0mm² to H05V2V2-F.
- Cable 2(heater): Heat resistant PVC 3-core flexible cable 2.5mm² to H05V2V2-F.
- Additional equipment wired to the product must comply with the latest IET wiring regulations.

4.2.2 Explanations for the hydraulic configuration

General	
XCU-THH (XCU HY)	Installer module integrated into the indoor unit
UI800	User interface
CR10	Room controller (accessories)
T1	Outside temperature sensor
PW2	DHW circulation pump (accessories)
TW1	DHW temperature sensor
Heating circuit without mixing valve	
PC1	Circulation pump for heating circuit
MC1	Safety thermostat

4.3 Water quality

4.3.1 Quality requirements for the heating water

The quality of the fill and top-up water is an essential factor for increased efficiency, functional reliability, long service life and for maintaining the operational readiness of a heating system.



Unsuitable water can damage the heat exchanger or cause a fault in the heat generator or DHW supply!

Unsuitable or contaminated water can lead to sludge formation, corrosion or scaling. Unsuitable antifreeze or hot water additives (inhibitors or anti-corrosion agents) can damage the heat generator and heating system.

- ▶ Only fill the heating system with potable water. Do not use well or groundwater.
- ▶ Determine the water hardness of the filling water, before filling the system.
- ▶ Flush the heating system prior to filling.
- ▶ If magnetite (iron oxide) is present, anti-corrosion measures are required and the installation of a magnetite separator and a de-airing valve in the heating system is recommended.
- ▶ The limit values in table 3 must not be exceeded, even if national directives contain higher limits.

Water quality	Unit	Value
Conductivity	µS/cm	≤ 2500
pH		≥ 6,5... ≤ 9,5
Chloride	ppm	≤ 250
Sulphate	ppm	≤ 250
Sodium	ppm	≤ 200

Table 3 Boundary conditions for potable water (filling water)

- ▶ Check the pH value after > 3 months of operation. Ideally at the first service.

Material of heat generator	Heating water	pH value range
Copper brazed heat exchangers	• Untreated potable water • Fully softened water	7.5 ¹⁾ – 10.0
	• Low-salt operation < 100 µS/cm	7.0 ¹⁾ – 10.0

1) If pH value is < 8.2 an on-site test for ferrous corrosion is necessary

Table 4 pH value ranges after > 3 months of operation

- ▶ Treat the fill and top up water according to the instructions in the following section.

Depending on the hardness of the filling water, the system water volume and the maximum heat output of the heat generator, water treatment may be required to avoid a damage in water heating installations, due to the formation of lime scale.

Requirements on the fill and top-up water

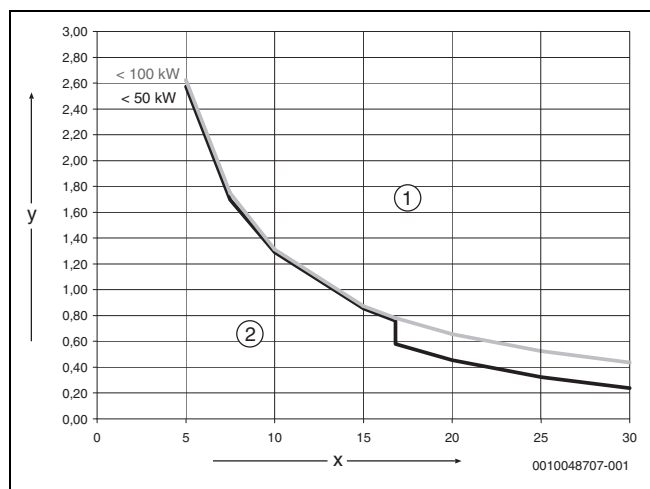

Fig. 14 Heat generators < 50 kW-100 kW

- [x] Total hardness in °dH
- [y] Maximum possible water volume over the service life of the heat source in m³
- [1] Above the curve, only use desalinated fill and top-up water, with a conductivity of ≤ 10 µS/cm
- [2] Below the curve, untreated fill and top-up water according to drinking water regulation can be used



For systems with a specific system water content >40 l/kW, water treatment is mandatory. If there are several heat generators in the heating system, then the system water volume must be related to the heat generator with the lowest output.

Water hardness unit conversion					
	°dH	°e	°fH	ppm	mmol/l
1°dH=	1	1,25	1,8	17,8	0,1783
1°e=	0,798	1	1,4	14,3	0,142
1°fH=	0,56	0,7	1	10	0,1
1 ppm CaCO3 (USA)	0,056	0,07	0,1	1	0,01
1mmol/l=	5,6	7,02	10	100	1

Table 5 Water hardness unit conversion

A recommended and approved method for water treatment is desalination of the fill and top-up water to a conductivity of ≤ 10 µS/cm.

Prevention of corrosion

In most cases, corrosion plays only a minor role in heating systems. However, a precondition for this is that the system is a corrosion-sealed water heating installation. This means that there is practically no access of oxygen to the system during operation.

Continuous introduction of oxygen leads to corrosion and can thus cause rusting and rust sludge formation. Sludge formation can not only cause blockages and therefore a diminished heat supply but also deposits (similar to lime scale deposits) on the hot surfaces of the heat exchanger.

The amount of oxygen introduced by the fill- and top-up water are generally very small and can therefore be ignored.

To avoid oxygenation, connection pipes must be diffusion-tight! The use of rubber hoses should be avoided.

The intended connection accessories should be used in the installation.

During operation, pressure maintenance with regard to oxygen ingress and in particular the function, correct sizing and correct setting (pre-charge pressure) of the expansion vessel is of highest importance. Check the pre-charge pressure and function annually.

Furthermore, the function of automatic air vents should also be checked during maintenance.

It is also important to check and document the top-up water quantities via a water meter. Larger and regularly required water top-up quantities indicate insufficient pressure maintenance, leaks or continuous oxygen input.

Antifreeze



Unsuitable antifreeze can damage the heat exchanger or cause a fault in the heat source or DHW supply.

Unsuitable antifreeze can damage the heat source and heating system. Only use antifreeze as listed in the document 6720841872, which contains antifreeze products approved by us.

- ▶ Only use antifreeze according to the specifications of the manufacturer, e.g with regard to the minimum concentration.
- ▶ Follow the instructions of the manufacturer of the antifreeze about regular checking of the concentration and corrective measures.
- ▶ The use of antifreeze reduces the efficiency.

Heating water additives



Unsuitable heating water additives can cause damage to the heat source and heating system or cause a fault in the heat source or DHW supply.

The use of a heating water additive, e.g. corrosion inhibitor, is only allowed, if the manufacturer of the heating water additive certifies its suitability for all materials in the heating system.

- ▶ Only use heating water additives in accordance with the instructions of its manufacturer about concentration, regular checking of the concentration and corrective measures.

Sealants in the heating water can cause deposits in the heat generator, therefore it is not advisable to use it.

Suitable water treatment products (inhibitors/cleaners) can be obtained from the following manufacturers:



Follow the guidance of BS7593:2019¹⁾ for treatment of water in domestic hot water heating systems.

ADEY	www.adey.com
FERNOX	www.fernox.com
SENTINEL	www.sentinelprotects.com/uk

Table 6

4.3.2 Water quality for potable water (DHW)

The integrated domestic hot water cylinder is constructed to heat and store potable water. Follow country-specific regulations and standards for potable water. The water quality in the cylinder has to comply with the framework of EU directive 2020/2184.

Use in hard water areas:

In areas where temporary water hardness exceeds 200ppm (11.2°dH), consideration should be given to reducing the dhw temperature to 50-55° C*. Additionally consideration may need to be given to the fitting of a scale prevention device. In such circumstances, the advice of the local water authority should be sought.

*Ensure legionella protection with the settings on the HMI!

Water mains pressure:

- Minimum mains water pressure, for maximum performance refer to section 13.1 "Technical specifications".
- Maximum mains fed water static pressure is 10 bar.

1) Only applicable in the United Kingdom

4.4 Minimum volume and execution of the heating system



Normally the energy for the defrost cycle is drawn from the buffer cylinder and the heating system, but in small systems with low flow the controller may switch to draw energy from the DHW cylinder instead. Even the electrical heater may be activated to ensure a proper defrost.

4.5 Check size of expansion vessel (central heating side)

Characteristic diagram for expansion vessel

Safety valve setting (bar)	3.0		
Vessel charge and initial system pressure (bar)	0.5	1.0	1.5
Total water content of system (litres)	Select an expansion vessel with a nominal volume not less than given below (litres)		
25	2.1	2.7	3.9
50	4.2	5.4	7.8
75	6.3	8.2	11.7
100	8.3	10.9	15.6
125	10.4	13.6	19.5
150	12.5	16.3	23.4
175	14.6	19.1	27.3
200	16.7	21.8	31.2
225	18.7	24.5	35.1
250	20.8	27.2	39.0
275	22.9	30.0	42.9
300	25.0	32.7	46.8
Multiplying factors for other system volumes	0.0833	0.109	0.156

Table 7 Capacities of expansion vessel

4.6 Pressure relief pipework



CAUTION

Scalding risk from hot water or steam!

- ▶ The pressure relief valve (PRV) and temperature & pressure relief valve (TPRV) are appliance safety devices and may discharge hot water or steam when activated.
- ▶ The outlet pipe should be sited in such a way that it does not cause a hazard or an obstruction when discharging, for example above a window, entrance door or other public access way.
- ▶ The point of termination should provide a visual indicator in case the PRV/TPRV discharges.

- The pressure relief discharge pipe [1 or 3] should be run in pipe which has a diameter of at least 15mm, that is made of copper or a material that will withstand PRV/TPRV discharge temperatures and pressures, and which complies with BS 5254 or BS EN 1451.
- Plastic pipework must be properly supported with a maximum of 300mm between supports to prevent sagging.
- The PRV discharge pipe must run continuously downwards away from the appliance to a safe point of discharge.
- The pressure relief should discharge away from any electrical or other hazard, preferably to an external drain or soak-away.
- The pipe [1 or 3] should be finished with a partial bend, to face the external wall (as shown) to ensure safe discharge of hot water.
- In all normal circumstances a PRV discharge pipe installation as described above sufficiently meets all but the most exceptional circumstances.
 - Where the PRV discharge pipe could be susceptible to damage, vandalism, freezing etc that could cause either a blockage or restriction in the ability to discharge safely then a tundish should be considered. The tundish should be sited in a position where damage to the property or injury to occupants cannot occur from any spillage or discharge.

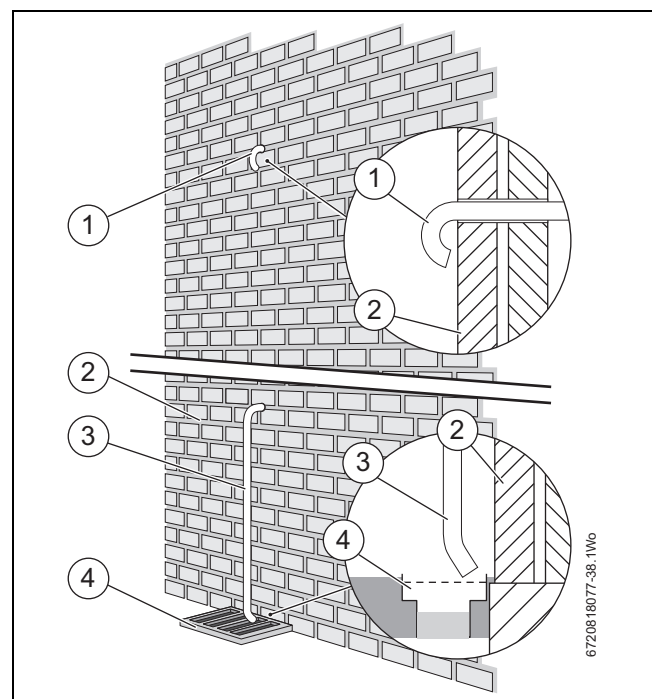

Fig. 15 Pressure relief pipework

- [1] Discharge pipe (turned back onto external wall example)
- [2] Outside wall
- [3] Discharge pipe (into drain or gully example)
- [4] External drain

4.7 Discharge Arrangement (DHW)

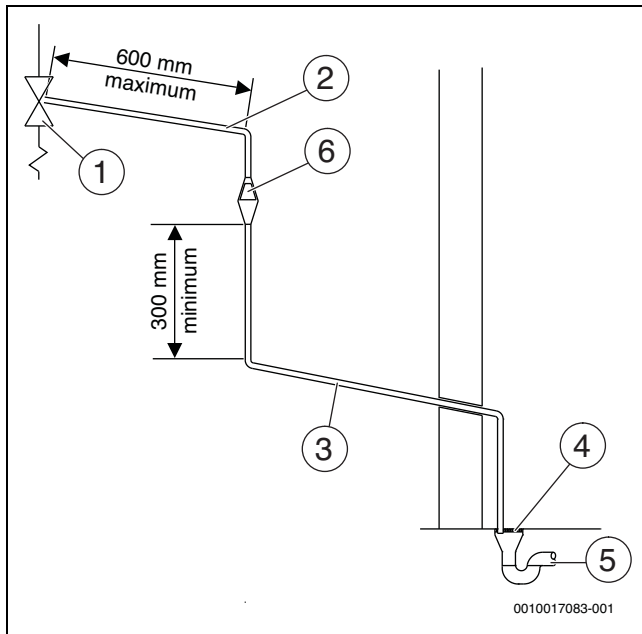

Fig. 16 Diagram of a typical discharge pipe arrangement (extract from Building Regulation G3)

- [1] Safety device (e.g. temperature relief valve)*
- [2] Metal discharge pipe (D1) from temperature relief valve to tundish*
- [3] Discharge pipe (D2) from tundish with continuous fall
- [4] Fixed grating
- [5] Trapped gulley
- [6] Tundish*

*The positions (1), (2) and (6) are already pre-installed on PPCy

Connect the Tundish and route the discharge pipe. The discharge pipework must be routed in accordance with Part G3 of schedule 1 of the Building Regulations. The information that follows is not exhaustive and if you are in doubt you should seek advice.

The two safety valves will only discharge water under fault conditions. When operating normally water will not be discharged.

The tundish should be vertical, located in the same space as the unvented hot water storage system and be fitted as close as possible and within 600mm of the safety device e.g. the temperature relief valve.

(all the above is already preplumbed)

The discharge pipe (D2) from the tundish should terminate in a safe place where there is no risk to persons in the vicinity of the discharge and:

- Be at least one pipe size larger than the nominal outlet size of the safety device unless its total equivalent hydraulic resistance exceeds that of a straight pipe 9 m long i.e. discharge pipes between 9 m and 18 m equivalent resistance length should be at least two sizes larger than the nominal outlet size of the safety device, between 18 and 27 m at least 3 sizes larger, and so on. Bends must be taken into account in calculating the flow resistance. Refer to Fig. 16, Table 8 and the worked example.

An alternative approach for sizing discharge pipes would be to follow British specification standards for design installation, testing and maintenance of services supplying water for domestic use within buildings and their curtilages.

- Have a vertical section of pipe at least 300 mm long, below the tundish before any elbows or bends in the pipework.
- Be installed with a continuous fall.
- It is preferable for the discharge to be visible at both the tundish and the final point of discharge but where this is not possible or practically difficult there should be clear visibility at one or other of these locations. Examples of acceptable discharge arrangements are:

- Ideally below the fixed grating and above the water seal in a trapped gulley.
- Downward discharges at a low level; i.e. up to 100 mm above external surfaces such as car parks, hard standing, grassed areas etc. are acceptable providing that where children play or otherwise come into contact with discharges, a wire cage or similar guard is positioned to prevent contact whilst maintaining visibility.
- Discharges at a high level; e.g. in to metal hopper and metal down pipe with the end of the discharge pipe clearly visible (tundish visible or not) or onto a roof capable of withstanding high temperature discharges of water and 3 m from any plastic guttering systems that would collect such discharges (tundish available).
- Where a single pipe serves a number of discharges, such as in blocks of flats, the number served should be limited to not more than 6 systems so that any installation can be traced reasonably easily. The single common discharge pipe should be at least one pipe size larger than the largest individual discharge pipe to be connected. If unvented hot water storage systems are installed where discharges from safety devices may not be apparent i.e. in dwellings occupied by blind, infirm or disabled people, consideration should be given to the installation of an electronically operated device to warn when discharge takes place.

NOTICE

- ▶ The discharge may consist of scalding water and steam. Asphalt, roofing felt and non-metallic rainwater goods may be damaged by such discharges.
- ▶ It is only acceptable to discharge into a soil pipe if certain conditions stipulated in the G3 regulations are met.

The table below is based on copper tube. Plastic pipes may be of different bore and resistance. Sizes and maximum lengths of plastic should be calculated using data prepared for the type of pipe being used.

Valve outlet size	Minimum size of discharge pipe D1 ¹⁾	Minimum size of discharge pipe D2 from tundish	Maximum resistance allowed, expressed as a length of straight pipe (i. e. no elbows or bends)	Resistance created by each elbow or bend
G1/2	15 mm	22 mm	up to 9 m	0.8 m
		28 mm	up to 18 m	1.0 m
		35 mm	up to 27 m	1.4 m
G3/4	22 mm	28 mm	up to 9 m	1.0 m
		35 mm	up to 18 m	1.4 m
		42 mm	up to 27 m	1.7 m
G1	28 mm	35 mm	up to 9 m	1.4 m
		42 mm	up to 18 m	1.7 m
		54 mm	up to 27 m	2.3 m

1) see Fig. 16

Table 8 Sizing of copper discharge pipe "D2" for common temperature relief valve outlet sizes

Worked example:

The example below is for a G1/2 temperature relief valve with a discharge pipe (D2) having 4 No. 22 mm elbows and length of 7 m from the tundish to the point of discharge.

From Table 8:

Maximum resistance allowed for a straight length of 22 mm copper discharge pipe (D2) from a G1/2 temperature relief valve is: 9.0 m

Subtract the resistance for 4 No. 22 mm elbows at 0.8 m each = 3.2 m

Therefore the maximum permitted length equates to 5.8 m which, is less than the actual length of 7 m therefore calculate the next largest size of discharge pipe (D2).

Maximum resistance allowed for a straight length of 28 mm copper discharge pipe (D2) from a G1/2 temperature relief valve is: 18 m

Subtract the resistance for 4 No. 28 mm elbows at 1.0 m each = 4 m

Therefore the maximum permitted length equates to: 14 m

As the actual length is 7 m, a 28 mm (D2) copper pipe will be satisfactory.

4.8 Cleaning primary systems

NOTICE

Risk of damage to system or appliance!

Debris from the system can damage the appliance and reduce efficiency. Failure to comply with the guidelines for the use of water treatment with the appliance will invalidate the appliance guarantee and contravene the Building Regulations.

- ▶ It is a requirement of the Building Services Compliance Guide which is a second tier document to the Building Regulations to flush and inhibit the primary water system in accordance with BS 7593.
- ▶ The Building Services Compliance Guide recommends that a primary water cleanser is fitted to the system.
- ▶ The filter fitted to the appliance will help remove both magnetite and non-magnetic debris.

NOTICE

Risk of damage to system or appliance!

- ▶ Salt based, artificially softened water that adjusts the pH value MUST NOT be used to fill the system.
- ▶ Alternatively there are water softening/treatment products that do not adjust or alter the pH levels of the water. With these products it may not be necessary to provide an untreated water by-pass to the primary water filling point of the heat system

Before cleaning the system:

- ▶ Ensure that the system and pipework is in good working order.
- ▶ **Where possible keep the existing appliance/circulating pump in place when flushing the system before installing the new appliance. Alternatively use an after market power flushing system or similar to remove magnetite and other debris from the central heating system.**
 - Even new central heating systems contain contaminants that need to be removed before treating the system with inhibitor/anti-freeze.
 - When an appliance is installed onto a new system then it is possible to use the appliance whilst cleaning the system. A system filter must be fitted to the return to reduce the risk of contaminants entering the appliance.
- ▶ **Follow the guidance of BS7593.**

4.8.1 Flushing the system

Flushing the system using existing appliance/circulating pump or new appliance.



Existing appliances/circulation pumps

- ▶ An existing appliance/circulating pump should be used to flush the system before the new appliance is installed.



New appliances

- ▶ A new appliance must only be used to assist the cleaning of a **newly installed** system.
 - ▶ Fill the system with cold water and check for leaks.
 - ▶ Open all drain cocks and drain the system.
 - ▶ Close drain cocks and add a suitable flushing agent at the correct strength for the system conditions in accordance with the manufacturer's instructions.
 - ▶ Mark the position of the lockshield valves and open them fully.
 - ▶ Fully open all TRVs.
 - ▶ Circulate the flushing agent before the appliance is fired up.
 - ▶ Run the appliance/system at normal operating temperature as directed by the manufacturer of the flushing agent.
 - ▶ Drain and thoroughly flush the system to remove the flushing agent and debris. Do not drain the system through the PRV of new appliances.

- ▶ It may be necessary to use a power flushing machine to aid the cleansing procedure in some circumstances.
- ▶ Close the drain cocks and manual air vents.

For existing appliance/circulating pump actions.

- ▶ Add a suitable inhibitor to the system in accordance with the manufacturers instructions.
- ▶ Fill the system to between 0.8 and 1.7 bar via a WRAS approved filling loop (supplied with the appliance)
- ▶ Vent any air from the appliance and system.

For new appliance.

- ▶ Once the new appliance has been installed follow the guidance in Filling the appliance and adding additive, see section Heating water additives.

5 Installation

 **CAUTION**

Risk of injury!

During transport and installation there is a risk of crushing injury. During maintenance, internal parts of the appliance may become hot.

- ▶ The installer is obliged to wear gloves during transport, installation and maintenance.

5.1 Transport and storage

The indoor unit must always be transported and stored in an upright position. If needed, it may be leaned temporarily.

The indoor unit may not be stored or transported at temperatures below - 10 °C.

5.2 Moving the appliance to the installation place

 Never lift the cylinder by the pipes. Lifting is only allowed via lifting straps at the top the cylinder.

 Two people are needed when unpacking, holding and moving the cylinder. There is a risk of it falling over

 Retain the brackets to secure the cylinder in place

 As soon as the brackets are released, the cylinder must always be held tightly or otherwise fixed in place.

- ▶ Remove the strapping tape, top cap and sleeve
- ▶ Hold the cylinder at the handles so that it can not fall over
- ▶ Unscrew the bolts from the pallet, holding the cylinder and remove the brackets.
- ▶ Keep the brackets for the later fastening of the cylinder.

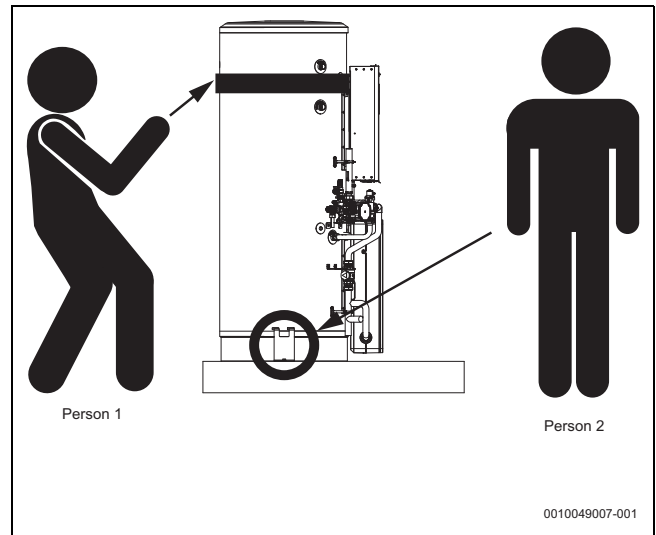

Fig. 17 Bracket removal: person 2 removes the brackets while person 1 holds the cylinder.

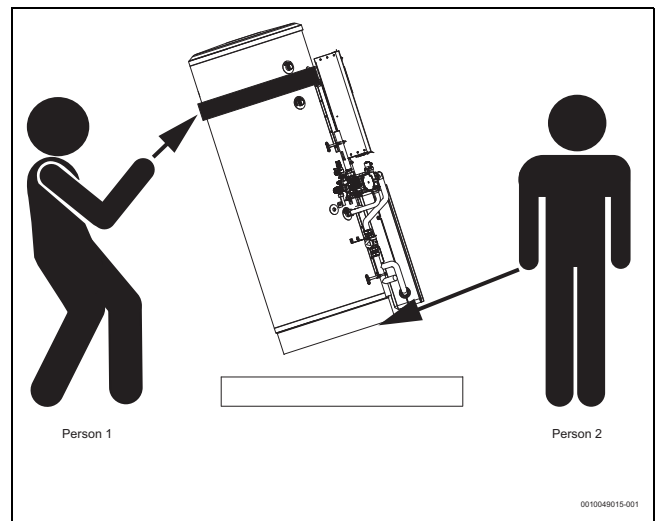



Fig. 18 Lifting the 180 SL and 210 L and 250 L cylinder. Tilt and touch the cylinder before lifting. Person 1 pulls the cylinder closer while person 2 supports the base. (210 L and 250 L have a additional handhold in the underside base insert)

 As soon as the brackets are released, the cylinder must always be held tightly or otherwise fixed in place

 Do not load the cylinder from the front

- ▶ Use a transport trolley to move the appliance to it installation place.
- ▶ Loaded from behind to avoid tipping over sideways and held permanently
- ▶ attach additional straps to secure the safe hold on the trolley

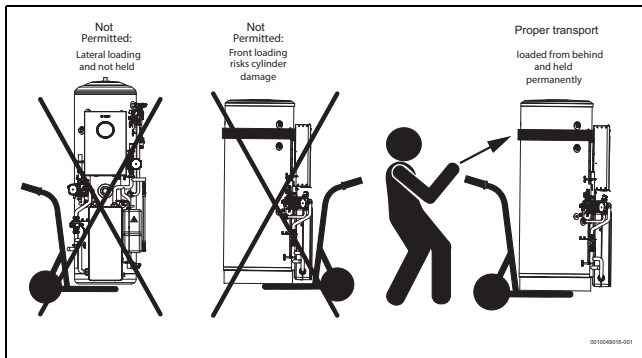

Fig. 19 Requirement for appliance transport with trolley: Danger of tipping (left), danger of cylinder damage loading from the front (middle) and appropriate transport permanently holding the appliance (right)

5.3 Fastening the cylinder to the ground



Product positioning

- ▶ Ensure the filled product is mounted onto a flat, fixed rigid surface capable of supporting the product weight.
- ▶ Ensure all aspects of the installation are considered when positioning the product, connecting pipework, maintenance access etc.
- ▶ Ensure the product is fixed to floor using the provided mounting brackets.

5.4 Installation checklist



Each installation is unique. The following checklist provides a general description of how the installation should be performed.

1. Install the fill valve.
2. Install the PRV pipe work.
3. Connect heat pump to the indoor unit.
4. Connect the indoor unit to the heating system.
5. Install a magnetite separator (magnetite separator is only optional for new building with only under-floor heating system).
6. Connect the mains water supply to the indoor unit and the pressure-relief valve.
7. Mount the outside temperature sensor and any room controller (room controller optional).
8. Connect the CAN-BUS cable to the heat pump and the indoor unit.
9. Install any accessories.
10. Connect the EMS-BUS cable to accessories if needed.
11. Fill and vent the DHW cylinder.
12. Fill and vent the heating system before commissioning.
13. Establish the electrical connection of the system.
14. Commission the system.
15. Vent the heating system also during the commissioning.

Product connections

NOTICE

Appliance - hydraulic connections

- ▶ Ensure all water pipework, to be connected, is isolated/drained and follow all relevant safety precautions.
- ▶ Be careful of plastic and adjacent components when using a naked flame on pipework.
- ▶ Check tightness of compression fittings on appliance before filling the system.



Surplus water may be present inside the appliance due to factory testing.

5.5 Installation of accessories

Placement of the Connect-Key K30RF



You can find information on the Connect-Key K30RF, the WIFI connection, establishing the connection with the Internet and integration of accessories in the corresponding app and in the packaging of the Connect-Key K30RF.

- ▶ Place the module in the holder (→[1], figure 20). A LED will flash when properly inserted.

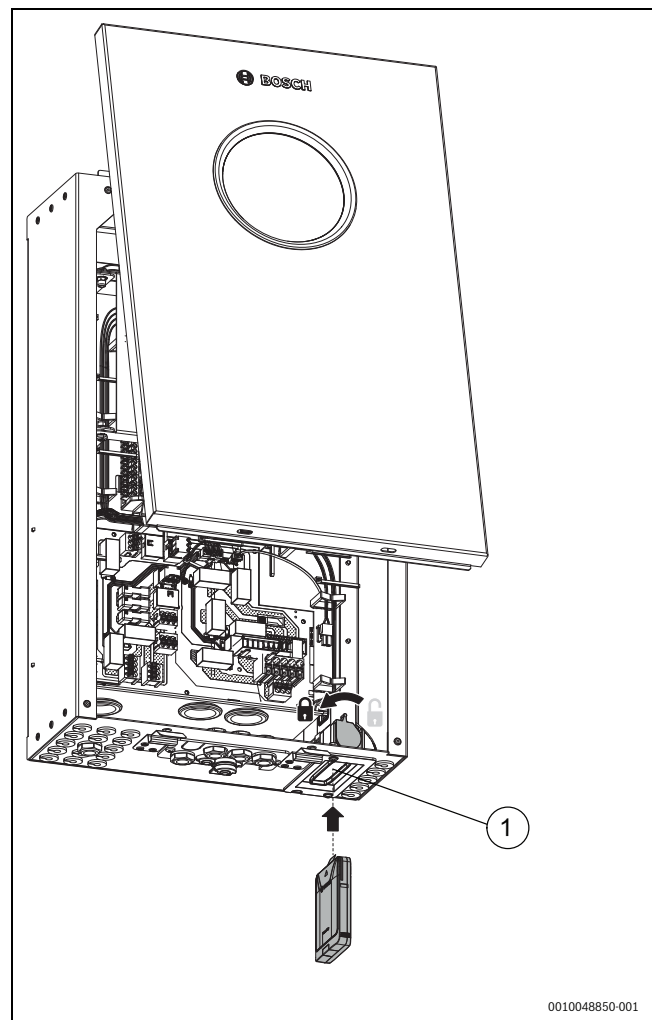

Fig. 20 Connect-Key K30RF placement

5.5.1 Safety thermostat

In some countries, a safety thermostat is required to be installed in under floor heating circuits. The safety temperature limiter is connected to external input 3. Set the operation for external input (→ control unit manual).

It is recommended to use a safety thermostat with automatic reset.



If the switching temperature of the safety thermostat is set too low or the thermostat is placed too close to the indoor unit, this may lead to a temporary blockage of the heating circuit pump PC1 and the heat sources after DHW charging.

- ▶ Set a temperature that is suited for the floor.
- ▶ Place the thermostat at least >1m from the indoor unit.

5.6 Remove covers

NOTICE

Transport protection covers

- ▶ Remove any internal transport packaging and protection covers from the product where applicable.

6 Hydraulic connections

NOTICE

Residue in the pipework can damage the system.

Solids, metal/plastic filings, flux and thread tape residue and similar material can get stuck in pumps, valves and heat exchangers.

- ▶ Keep foreign bodies from entering the pipework.
- ▶ Do not leave pipe parts and connections directly on the ground.
- ▶ When deburring, make sure that no residue remains in the pipe.
- ▶ Before connecting the heat pump and indoor unit, rinse the pipe system to remove any foreign bodies.



If Installation is done without a heating circuit, the pipes needs to be capped.

- ▶ Put caps on the flow- and return pipes to the heating system.

6.1 Insulation

NOTICE

Material damage due to frost and UV radiation

In case of a power outage the water pipes in the pipes may freeze.

The insulation may become brittle due to UV radiation and crack after some time.

- ▶ Use insulation with a thickness of at least 19mm for pipework and connections outdoors.
- ▶ Install drain valves so that the water can be drained out of the lines to and from the heat pump if it is not going to be used for some time or if there is a risk of frost.
- ▶ Ensure the drain valves are insulated.
- ▶ Use UV and moisture resistant insulation.
- ▶ Insulate the entire pipe length where it passes through the wall
- ▶ In buildings, use insulation with a thickness of at least 12mm for pipework. This is also important for safe and efficient DHW mode.

All heat-conducting pipework must be provided with suitable thermal insulation according to applicable regulations.

6.2 Pipe connections, general



Dimension the pipes according to the instructions (→table 9 and table 10)

- ▶ Avoid pipe joints in the heat transfer pipes to minimise pressure drop.
- ▶ Use PEX pipes for all connections between the heat pump and indoor unit.
- ▶ Use only material (pipes and connections) from the same PEX distributor to avoid leakage.
- ▶ Pre-insulated AluPEX pipes are recommended since they make installation easier and prevent gaps in the insulation. PEX or AluPEX pipes also devibrate and insulate against noise transfer to the heating system.



If a different material than PEX is used, the following is required:

- ▶ Install a particulate filter intended for outdoor use on the heat pump return line, directly on the heat exchanger.
- ▶ Insulate the particle filter as other connections.
- ▶ Ensure the pipe has flexibility to prevent vibrations from the heat pump connection with a hose intended for outside use and insulate it.

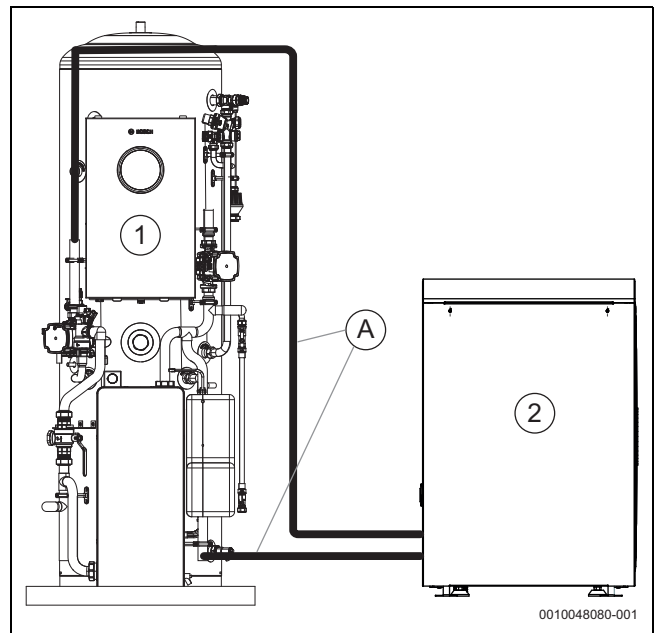

Fig. 21 Pipe length A

- [A] pipe length of flow return line
- [1] indoor unit
- [2] Heat pump

copper pipes (dimensions according to EN 1057)							
Heat Pump	Heat transfer fluid delta (K) ¹⁾	Nominal flow (L/min)	Δp (mbar) ²⁾	Outer Ø 15 (mm) Inner Ø 13,6 (mm)	Outer Ø 22 (mm) Inner Ø 20,2 (mm)	Outer Ø 28 (mm) Inner Ø 26.2 (mm)	Outer Ø 35 (mm) Inner Ø 32,6 (mm)
Maximum pipe length A (m), Figure 21							
4	5	11,5	469	12	30		
5	5	14,4	363	6	30		
7	5	20,2	74		5	18	30

1) Minimum dT at rated power and maximum pipe length. A lower dT can be achieved with lower heat requirements or short pipe lengths.

2) For pipes between the heat pump and indoor unit.

Table 9 Pipe dimensions and maximum pipe lengths (one-way) for connecting a heat pump to indoor unit

PEX pipes (dimensions according to EN 16893)						
Heat Pump	Heat transfer fluid delta (K) ¹⁾	Nominal flow (L/min)	Δp (mbar) ²⁾	Outer Ø 25 (mm) Inner Ø 20,4 (mm)	Outer Ø 32 (mm) Inner Ø 26,2 (mm)	Outer Ø 40 (mm) Inner Ø 32,4 (mm)
Maximum pipe length A (m), Figure 21						
4	5	11,5	469	30		
5	5	14,4	363	30		
7	5	20,2	74	5	16	30

1) Minimum dT at rated power and maximum pipe length. A lower dT can be achieved with lower heat requirements or short pipe lengths.

2) For pipes between the heat pump and indoor unit.

Table 10 Pipe dimensions and maximum pipe lengths (one-way) for connecting a heat pump to indoor unit

6.3 Connect the indoor unit to the heat pump

- ▶ Fit magnetic filter (advised). if no filter is fitted an isolation valve (VC5) should be installed
- ▶ install an isolation valve (VC4) on flow to PPC from ODU (inside the building)
- ▶ Install air vents (VL1) at the highest point of the flow and return pipes
- ▶ Install a drain valve close to the ODU and insulate (VC7)
- ▶ Connect the flow line from the heat pump to the heat transfer medium in
- ▶ Connect the return line to the heat pump to the heat transfer medium out.

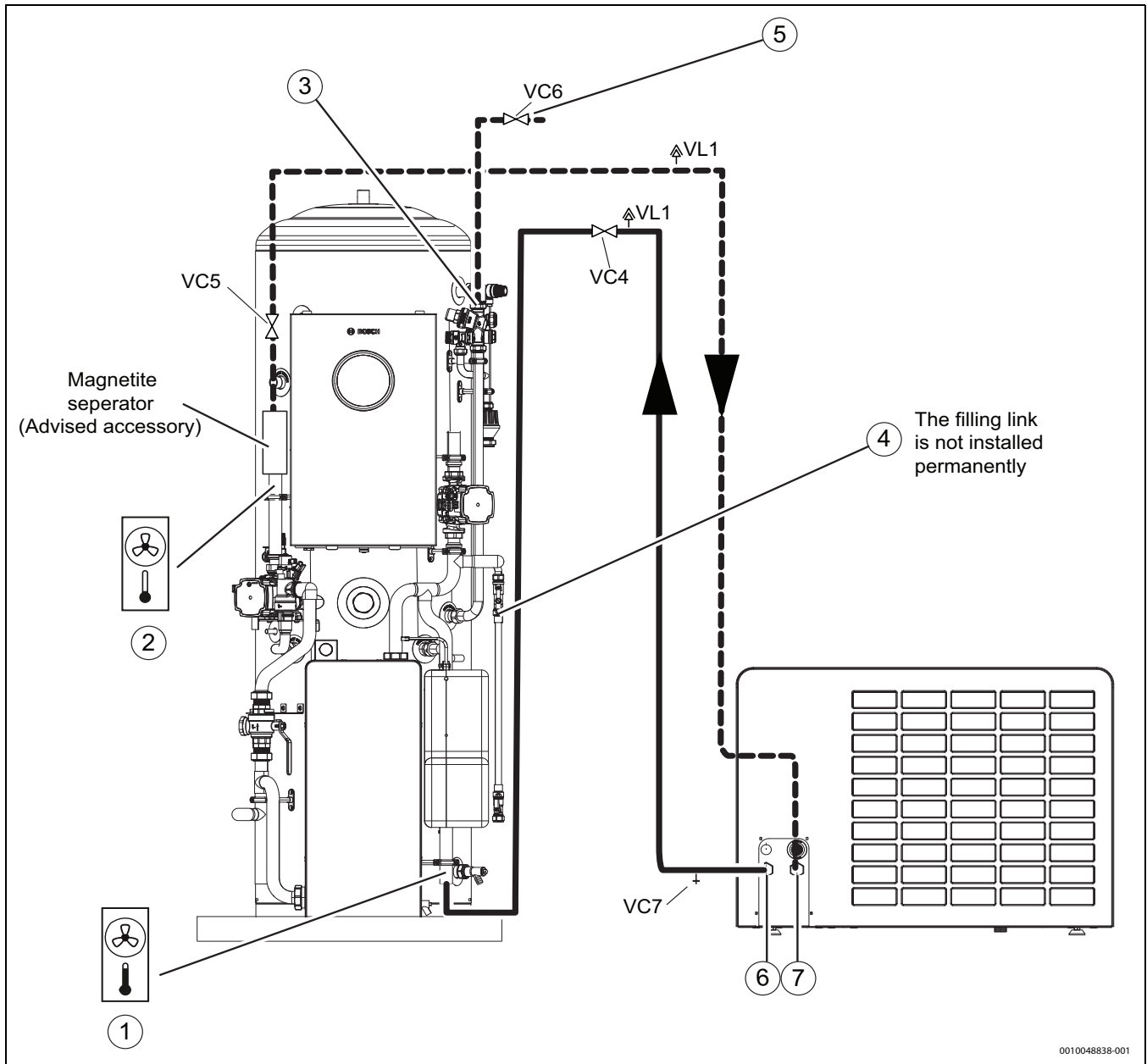

Fig. 22 Connect the indoor unit to the heat pump

- [1] Heat transfer medium in (from heat pump)
- [2] Heat transfer medium out (to the heat pump)
- [3] Cold main inlet control group (feed)
- [4] Filling link with 2 x VW (to be connected first)
- [5] Cold main isolation VC6
- [6] Flow line from the heat pump
- [7] Return line to the heat pump

6.4 Connect the indoor unit to the heating system

1. Connect PRV pipe work into a frost protect drain.
2. Connect the heating system return line. Install an isolation valve (VC8) in this line
3. Connect the heating system flow line. Install an isolation valve (VC9) in this line.

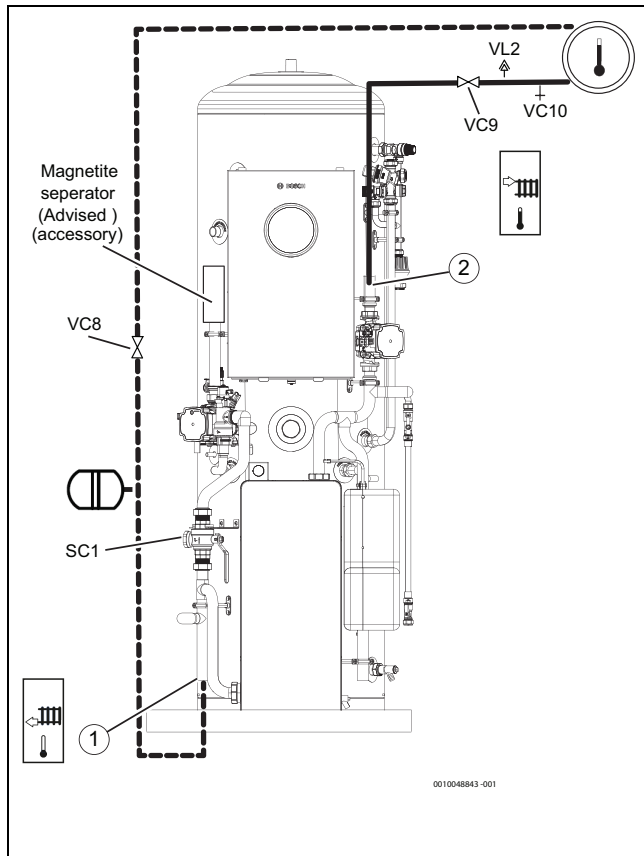

Fig. 23 Indoor unit connections to the heating system

- [1] Heating system return line
- [2] Heating system flow line

6.5 Connect the indoor unit to the mains water supply

 **WARNING**

Risk of system damage

If the function of the pressure-relief valve cannot be guaranteed, excessive pressure occurs in the system.

- ▶ **WARNING** – Make sure that the pressure relief valve outlet is never plugged or shut off.

 **WARNING**

Risk of scalding!

If the installation requires DHW temperatures >65 °C a temperature mixing device must be installed.



The DHW mixer must be installed in the tap water circuit (not included in the scope of delivery).

- ▶ Connect a discharge pipe from the tundish [6] to a frost protected outlet see section 4.7
- ▶ If used, connect the DHW circulation pump (optional accessory) to the secondary return connection [5]
- ▶ Connect domestic hot water outlet [1].
- ▶ Connect cold water inlet [2]. It is recommended to fit an isolating valve in cold water feed (not supplied).
- ▶ Connect the expansion vessel provided in the accessory pack to connection for it [4]
- ▶ The domestic tap water system must be protected from pollution at the installation

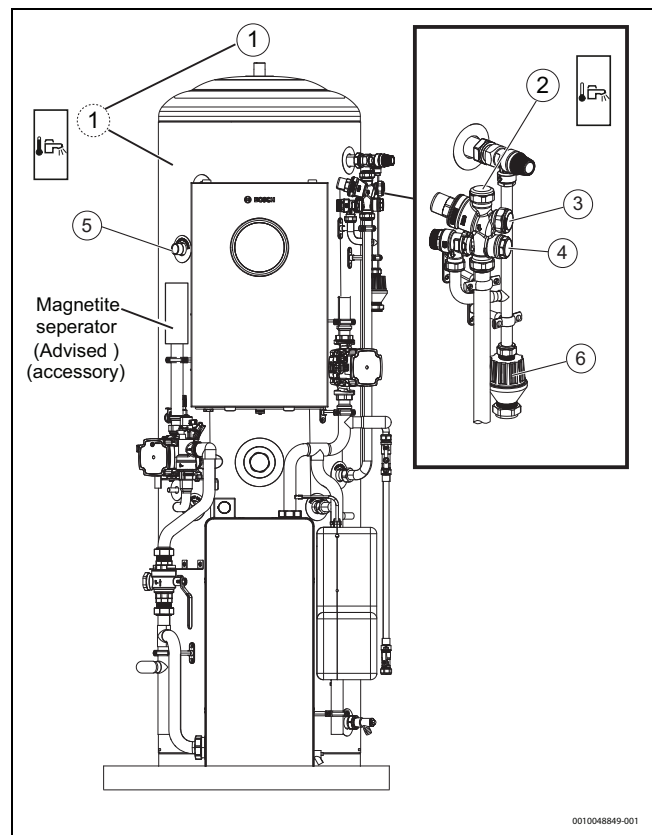

Fig. 24 Heat pump connections tap water

- [1] Domestic hot water out (210L & 250L on LH side)
- [2] Cold water inlet
- [3] Balance cold feed
- [4] DHW expansion vessel connection
- [5] DHW circulation connection
- [6] Tundish

6.6 Heat pump, indoor unit and heating system filling

NOTICE

The system will be damaged if it is powered up without water.

- ▶ Fill the DHW cylinder and heating system **before** powering on the heating system, and establish the correct pressure.

NOTICE

If the system is not correctly ventilated (purged), this will damage the indoor unit!

The auxiliary heater may overheat or be damaged if it has not been fully vented prior to activation.

- ▶ Carefully vent the system when filling.
- ▶ Carefully vent the system once again during commissioning.



CAUTION

Health risk caused by pollution of drinking water !

Prior to tap water filling:

- ▶ Flush tank and tap water hydraulic.
- ▶ Perform tap water system tightness test.



Tightness test must be done with mains water supply only. Test pressure at warm water side shall not exceed 10 bar.



Vent also by other ventilation valves in the heating system, e.g. radiators.



Fill preferably to a higher pressure than the final one so that there is a margin when the temperature of the heating system rises and the air that has been dissolved in the water is vented out via the venting valves.



At delivery the default position of the three-way valve VW1 is in middle position.

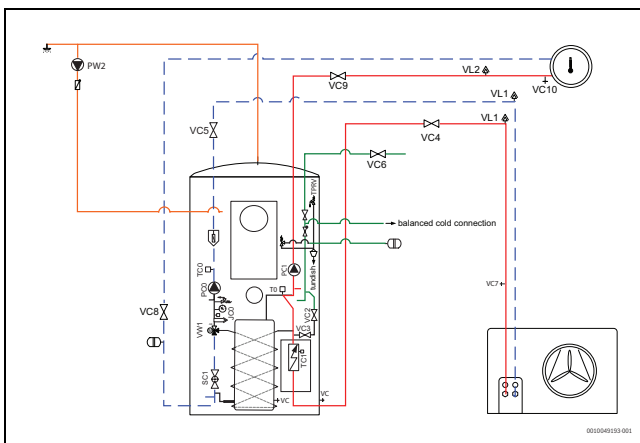

Fig. 25 Indoor unit, heat pump and heating system



This filling procedure is valid for all systems, also where the heat pump is placed above the indoor unit. For a less complex system the procedure may be simplified.

1. Ensure the power is off to the heat pump and the indoor unit. Ensure that all temperature regulation valves in the heating system are fully open.
2. Close the valves to the heating system (VC8 & VC9), the particle filter SC1, and the valves between heat pump and indoor unit (VC4 & VC5).
3. Check that the 3-way valve (VW1) is in middle position.
4. Attach the hose of the filling loop to the system fill isolation valves (VC2 & VC3). Ensure both ends of the hose are screwed on hand tight and valves VC2 & VC3 are closed.

Step 1: Filling the DHW cylinder

1. Open the cold mains isolation valve VC6
2. Open a hot water tap to fill the cylinder. Close the tap when only water emerges.
3. Check all compression fittings for tightness.

Step 2: Filling the heat pump and heating system

1. Connect a hose to the drain valve VC7 and the other end to an outlet. Keep VC7 closed.
2. Open the system fill valves VC2 and VC3 and isolation valve VC5 to fill the heat pump. Continue filling until no more air emerges from automatic air vents VL1.
3. Open VC7 and keep open until only water comes out of the hose by the drain and there are no more bubbles in the heat pump.
4. Open the isolation valve VC4.
5. Close the drain valve VC7 and fill valves VC2 & VC3.
6. Disconnect the hose from VC7 and move it to the heating system drain valve VC10.
7. Open the particle filter SC1, isolation valve VC8, and the fill valves VC2 & VC3 to fill the heating system. Continue filling until no more air emerges from automatic air vents VL2.
8. Open VC10 and continue filling until only water comes out of the hose by drain.
9. Open the valve VC9. Continue filling until only water comes out of the hose by the drain and there are no bubbles in the heating system.
10. Close the drain valve VC10 and remove the hose.
11. Open the manual air vent valve (behind the PC0 pump) and close them when only water emerges. Continue filling until the pressure gauge on the indoor unit reads between 1.3 to 1.5 bar.
12. Close the fill valves VC2 & VC3.
13. Disconnect the external filling loop refit the blanking caps.
14. Store the braided hose close to indoor unit after system filling.

7 Electrical connection

DANGER

Risk of electric shock!

- ▶ **This appliance incorporates two electrical supply cables (230V AC)**
- ▶ Isolate electrical components from all power supplies (230 V AC) (fuse, circuit breaker) and secure against unintentional re-connection before carrying out any work. Information on safe isolation can be found in the Health and Safety Executive guidance HSG85.
- ▶ Check for zero potential before proceeding with work, using test equipment approved to GS38 to confirm that the electricity supply is disconnected.

Electrical considerations:

- ▶ All electrical work must be carried out by a competent and authorised person.
- ▶ All work must comply with the current IET Wiring Regulations.
- ▶ The isolators shall be situated next to the appliance for new systems and, where practicable, replacement appliances.
- ▶ Any additional components that are connected to the appliance that require 230 Volts must be connected within the appliance.
- ▶ The correct type of RCD must be employed where additional protection is required that is suitable for a low energy DC modulating pump according to IET wiring regulations.

7.1 Safety instructions

Danger to life from electric shock

Means to safely disconnect the unit from supply mains must be incorporated.

Do not operate the appliance without the front cover

The front cover of the control box must be attached before operating the appliance.

Malfunctions caused by electrical interference!

High-voltage cables (230/400 V) in the vicinity of communication- and sensor cables can cause the indoor unit to malfunction.

The system will be damaged if it is commissioned without water

- ▶ Only operate the device when it is filled with water and at the correct operating pressure.

7.2 Cable types

An overview of replaceable or external cables is shown in tables 13, 14 and 15

7.3 Cable routing

NOTICE

Risk of damage from hot appliance components.

Hot appliance components can damage electrical cables.

- ▶ Ensure all electrical cables are in the correct cable guides and away from hot appliance components.

Cable routing

- ▶ Run power cables separately from signal and sensor cables. Interference from power cables can induce spurious faults on signal cables, ensure that there is at least 100mm separation from each other.
- ▶ Ensure the cables are not stretched or tight.
- ▶ Avoid sharp edges.

7.3.1 Power cables

- ▶ The appliance is provided with both power cables. These emerge from the central area of the bottom of the electrical control box (fig 26).
- ▶ Route cables neatly to the rear of the appliance and clip to fixed surfaces in accordance with IET wiring regulations
- ▶ If a power cable is to be replaced, refer to sections 7.4 and 7.5
- ▶ A spare strain relief is supplied in the hardware pack, if required.

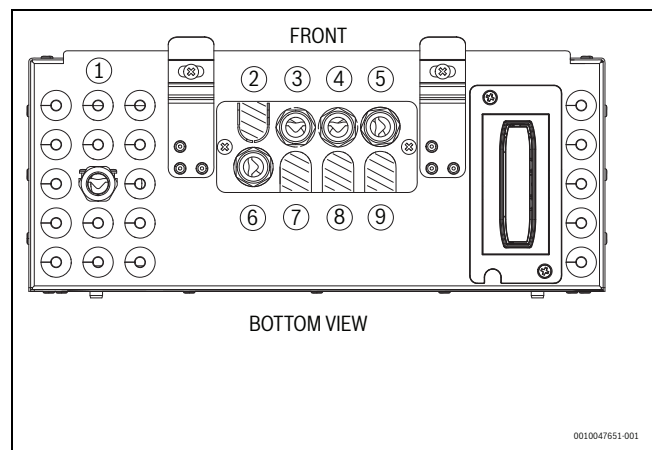

Fig. 26 Cable feeds to control box

- [1] Area for (low voltage) control and sensor cables
- [2] Accessory PC2 (plate cut out)
- [3] 230V control unit supply in
- [4] 230V heater supply in
- [5] 230V accessory MM100
- [6] 230V accessory PW2
- [7] Pump PC0 230V
- [8] Pump PC1 230V
- [9] Heater out 230V

7.3.2 Control and sensor cables

- ▶ The (low voltage accessory) control and sensor cables should be routed neatly to the rear of the appliance.
- ▶ Cables enter the left area of the bottom of the electrical control box via the bungs (fig 26)
- ▶ If a cable is to be installed or replaced, refer to sections 7.4 and 7.6

7.4 Access to control box

If access inside the control box is required, remove front cover (fig 27):

- ▶ Remove the two screws (1) at the bottom of the control box
- ▶ Push down the two spring clips
- ▶ Pull the bottom area of the front cover forwards and carefully lift the cover upwards to clear the two lugs at the top of the control box (2).
- ▶ Remove earth cable connector from tab at the inside lower edge of the door (3)(squeeze connector lug).

Fig 28 shows the two control boards revealed within the control box (note, cables not shown for clarity)

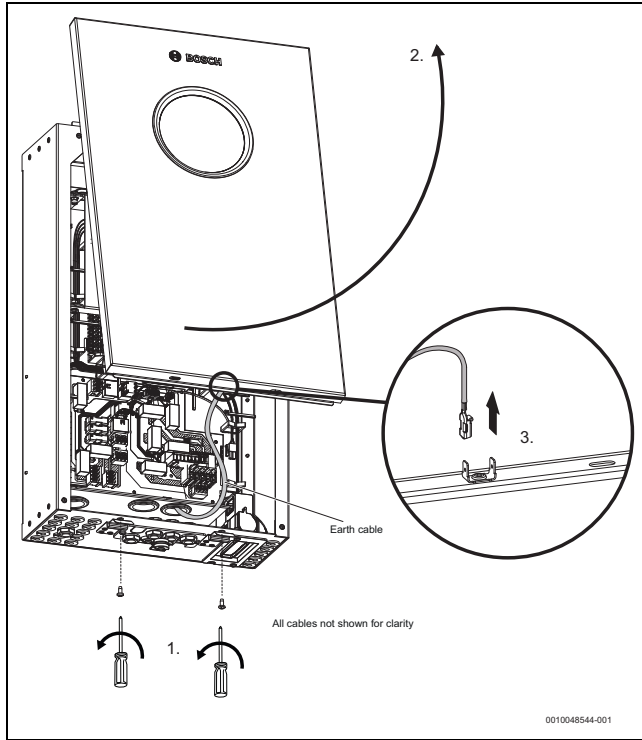

Fig. 27 Control box front cover removal

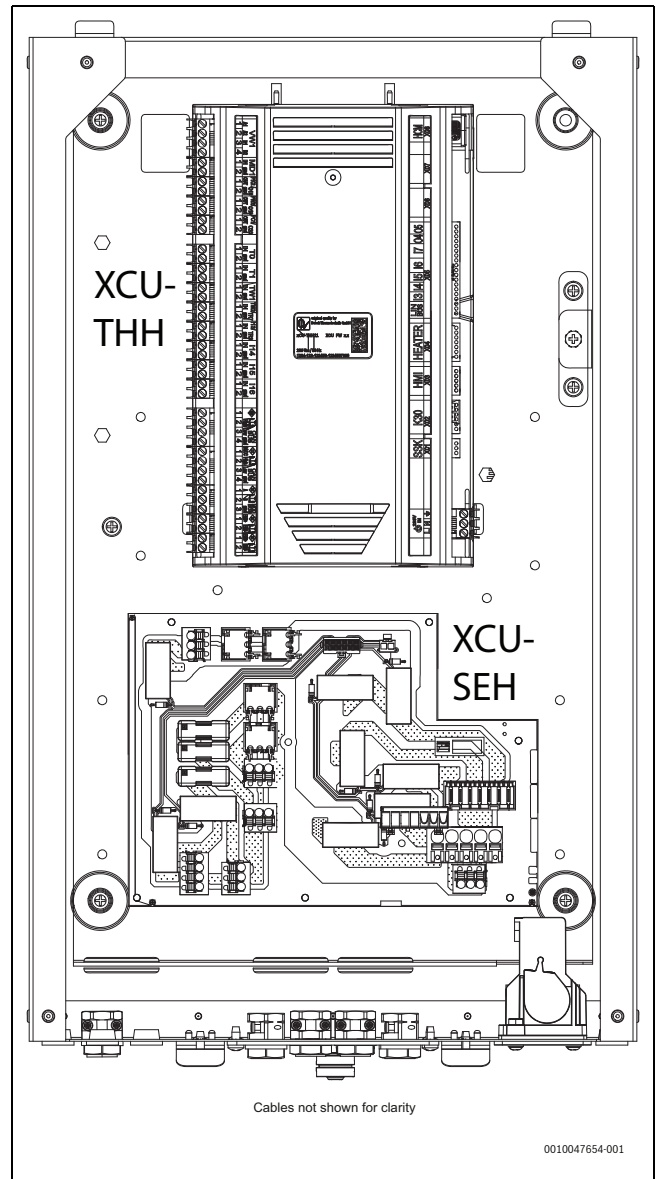

Fig. 28 Front view control box

7.5 Replacing/connecting the power cables

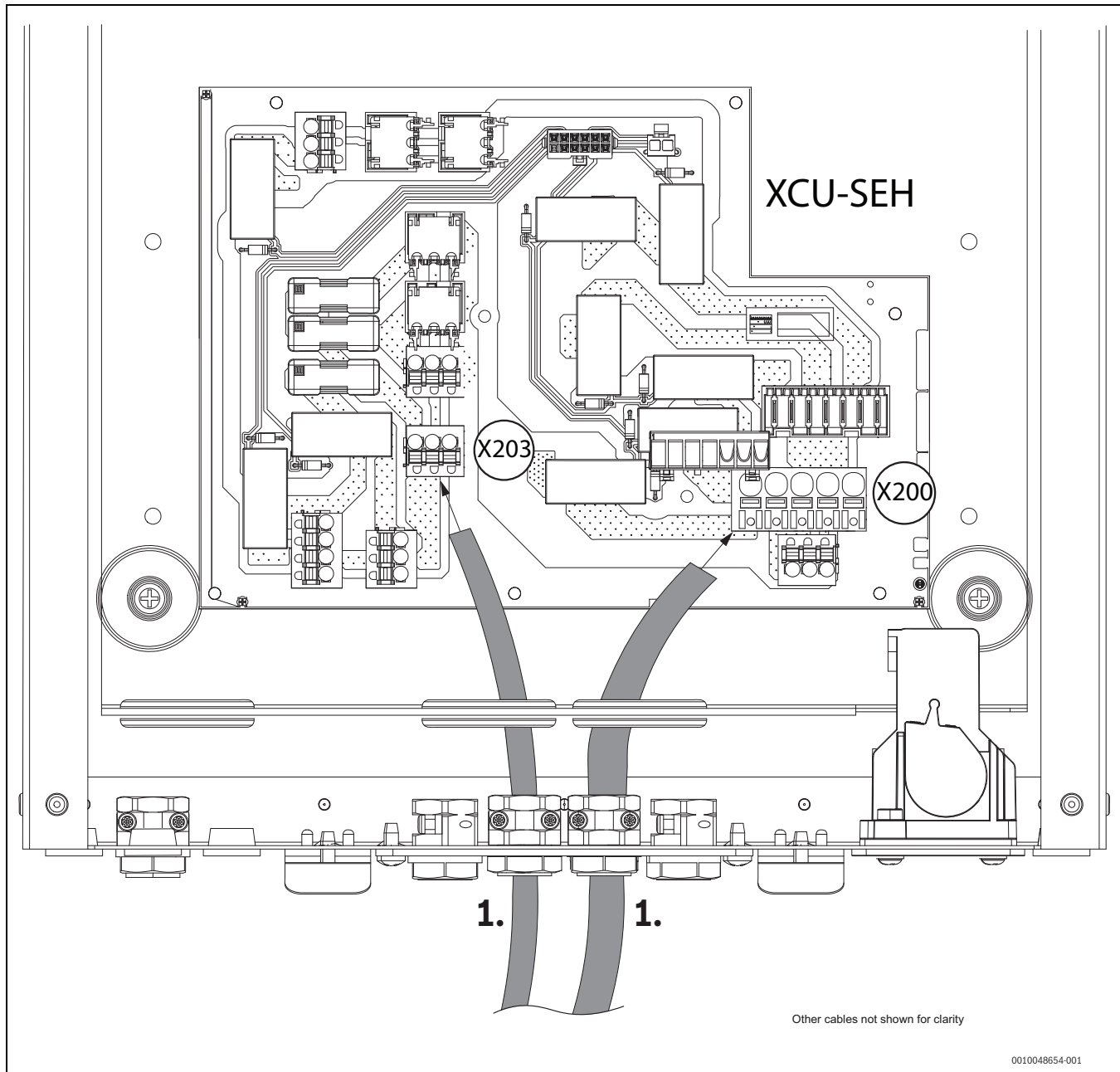

Fig. 29 Connecting the power supply cables

The appliance is delivered with both power cables fitted as shown in fig 29

- ▶ Connector X203: 230V supply to control unit.
- ▶ Connector X200: 230V supply to electric heater only.

If it is necessary to replace a supply cable (eg too short / damage etc) the associated cable gland (1) must be re-used such that the pull force resistance of 100N is assured.

7.5.1 Removal/replacement of 230V supply cables

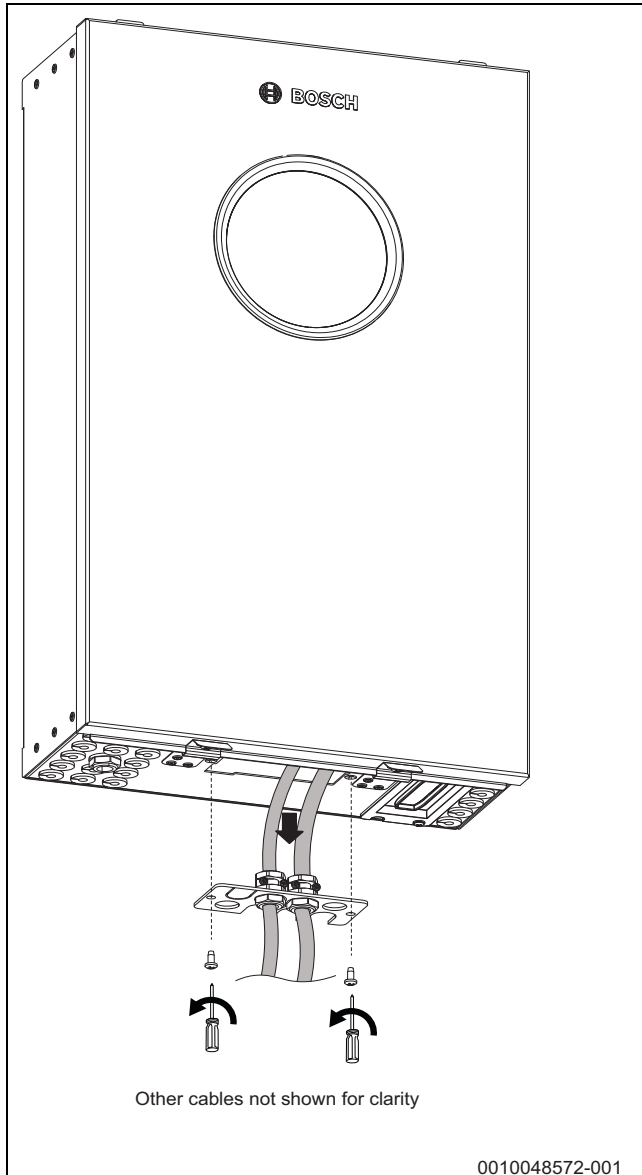

Fig. 30 Lowering the strain-relief plate

- For the best access to the cable gland, adopt the following sequence:
 - Disconnect and make safe cables from electrical supplies
 - Disconnect cable from selected connector on the control board (XCU-SEH). Note the connectors are the push in spring type. Push screwdriver (or similar) onto orange actuator in order to release the connector spring mechanism
 - Unscrew and carefully lower the strain-relief- plate as shown in fig 30 Lower the plate until resistance is felt, do not pull strongly to prevent damage to other cables/ connectors

- Remove gland nut (2) fig 31
- Push gland body upwards and out of the plate in order to manually grip on the gland body 1
- Loosen screws (3) and pull cable downwards and out of the gland and plate.
- Remove gland nut from cable

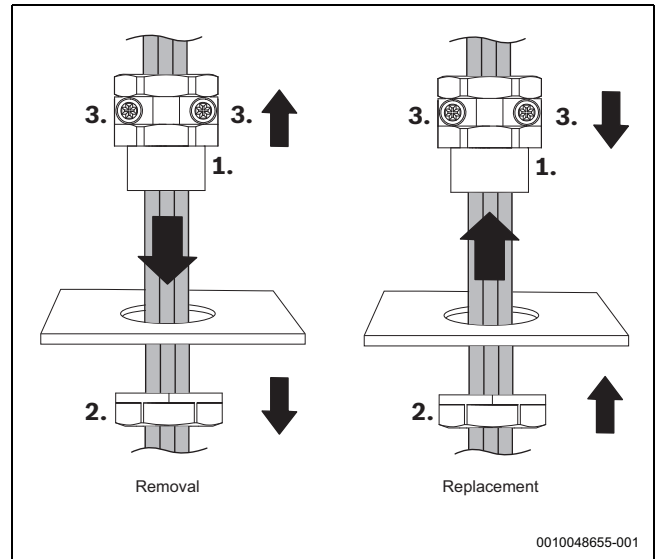

Fig. 31 Attaching/replacing cable glands

- For replacement cable type refer to tables 13, 14 and 15
- To replace cable:
 - Place gland nut (2) on new cable and feed cable up through plate hole and into gland body fig 31
 - With sufficient cable length to reach the connector, tighten gland screws (3) ensuring 100N pull force resistance
 - Fit gland body (1) into plate hole and fit / tighten nut (2)
 - Lift plate to bottom of control box and affix both securing screws
 - Strip cable outer sheath 60mm
 - Ensure the protective earth conductor is longer than the other wires
 - Strip cable core 12mm to fit into connector
 - Open connector spring mechanism fully insert cable conductor and release mechanism.

7.5.2 Connection of 230V supplies at the XCU-SEH unit

Key components on the control board are shown in section 7.5.4 for the 230V supplies:

- ▶ Item 1 shows the connector for the heater element. Note the terminals provide for a 3-phase supply : **terminals L2 and L3 must not be used**
- ▶ Item 3 shows the connector for the control unit

7.5.3 Connection of 230V accessories at the XCU-SEH unit

Key components on the control board are shown in section 7.5.4 for the 230V accessories:

- ▶ The connectors are listed for each accessory. Take note of connector type.
- ▶ Cable glands are provided. These should be fitted as described in section 7.5.1

7.5.4 Overview of connectors in the XCU-SEH area

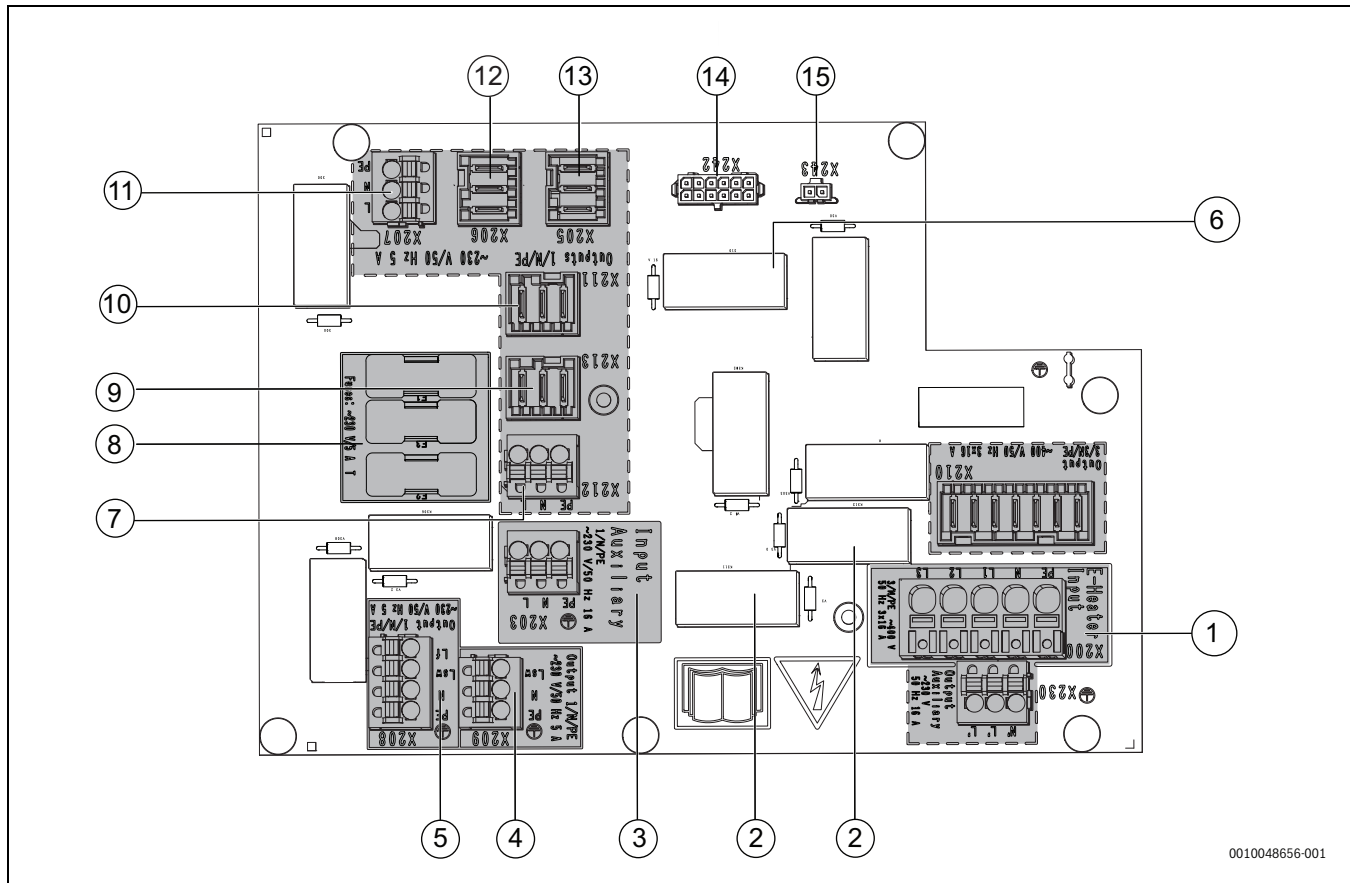

Fig. 32 Connections on circuit board

- [1] **X200**: 230V single phase connection for electrical heater element only
- [2] Safety relays for heater
- [3] **X203**: 230V single phase connection for control and pumps
- [4] **X209**: 230V output for accessory PK2
- [5] **X208**: 230V output for accessory PW2
- [6] Relay for pumps
- [7] **X212**: 230V output for accessory MM100 or pump group
- [8] Fuses 230V 5AT 20x5mm
- [9] **X213**: Not used
- [10] **X211**: 230V output for control board XCU-THH
- [11] **X207**: Not used
- [12] **X206**: 230V output for PC1
- [13] **X205**: 230V output for PC0
- [14] **X242**: low voltage internal wiring to control board XCU-THH
- [15] **X243**: low voltage input from heater element overheat cut off device

7.6 Connection of control and sensor cables

NOTICE

EMS-BUS and CAN-BUS are not compatible!

- ▶ Only connect CAN-BUS and EMS-BUS wiring to the correct connectors in the control box.

7.6.1 Installation/replacement of low voltage cables

- All low voltage cables are connected to the XCU-THH board. Access is gained as described in 7.4
- Cables for accessories should be fed through the bottom left area of the control box fig 26 and connected to the XCU-THH control unit as described in 7.6.6
- A white bracket is fixed to each side of control board XCU-SEH. This incorporates pairs of cut-outs to enable the low voltage cables (from the XCU-THH board) to be securely fixed by cable ties for strain relief purposes.
- Attach cable to cable-tie bracket, to ensure 100N pull resistance, as follows: ensuring sufficient slack of cable to the board, fix a 3.6mm-wide cable tie to the cable and secure it to the plate with two 2.5mm-wide ties as in show in fig 33. The heads of the ties must not be on the same side of the plate. This ensures minimum movement of cable.
- Fit white bung around cable beneath control box and push bung into control box hole.
- Any replaced cable must follow installation information above

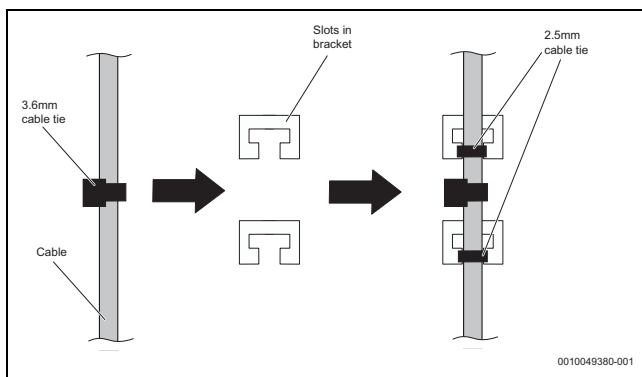

Fig. 33 Cable installation in cable bracket

7.6.2 CAN-BUS

NOTICE

The system will be damaged if the 24VDC- and the CAN-BUS connections are incorrectly connected!

The communication circuits are not designed for 24VDC constant voltage.

- ▶ Check to ensure that the cables are connected to the contacts with the corresponding markings on the modules.

NOTICE

Malfunction due to mixed up connections!

If the “High” (H) and “Low” (L) connections are mixed up, there is no communication between the heat pump and the indoor unit.

- ▶ Check to ensure that the cables are connected to the connections with the corresponding markings in both ends of the CAN-BUS cable.

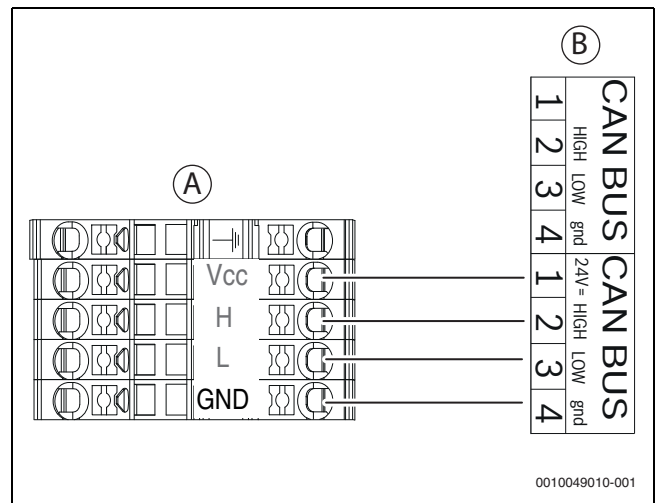

Fig. 34 CAN-BUS heat pump - indoor unit

- [A] Heat pump
- [B] Indoor unit
- [Vcc] 24V = (24VDC)
- [H] HIGH
- [L] LOW
- [GND] gnd

The heat pump and indoor unit are connected to each other by a communication line, the CAN-BUS [24VDC, class III (SELV)].

A LIYCY cable (TP) 2 x 2 x 0.75 (or equivalent) **is suitable as an extension cable outside of the unit.** In doing so, only earth the shielding on one side (indoor unit) and to the casing.

The maximum permissible cable length is 30 m.

The connection is made with four wires, as the 24VDC supply is also connected. The 24VDC and CAN-BUS connections are marked on the module.



The CANBUS cable has two pairs of twisted wires. Vcc and GND is one pair, H and L is the second pair. Maximum cable insulation stripping length for all cables is 120mm. Maximum wire stripping is between 8-10mm.

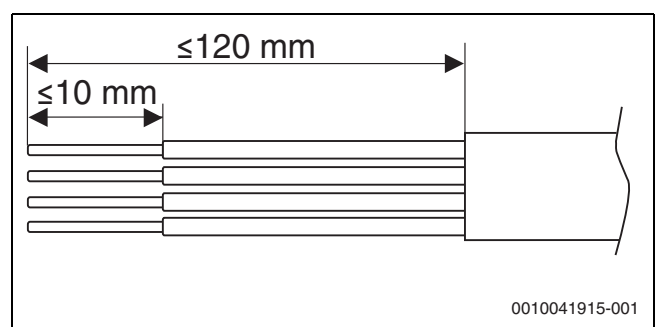

Fig. 35 Wire striping CAN-BUS

7.6.3 Installation of the temperature sensor

The user interface in the delivery configuration automatically regulates the flow temperature based on the outdoor temperature. A room temperature-dependent controller can be installed for greater comfort.

7.6.4 Outdoor temperature sensor T1

The cable to the outdoor temperature sensor must meet the following minimum requirements:

- Number conductors: 2
- Maximum length 30 m
- ▶ Install the sensor on the coldest side of the house, normally facing north. The sensor must be protected against direct sunlight, air vents or other factors which could affect the temperature measurement. The sensor must not be installed directly under the roof.
- ▶ Connect the outdoor temperature sensor T1 to the terminal T1 on the XCU-THH module within the electric box of the indoor unit.

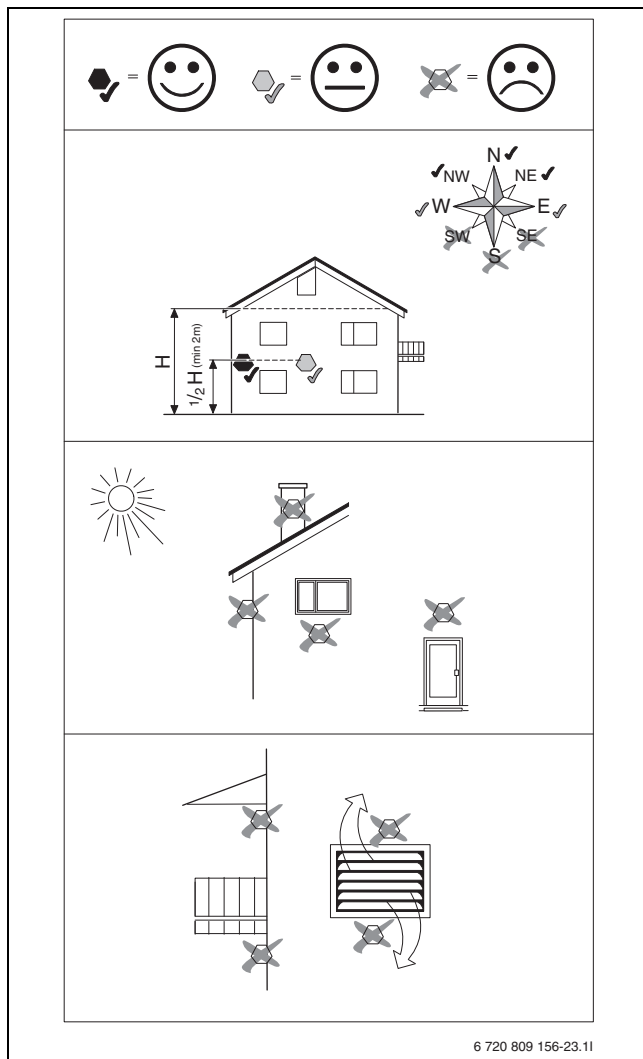

Fig. 36 Position of the outdoor temperature sensor

7.6.5 Flow temperature sensor T0

The sensor is already installed in the indoor unit.

7.6.6 External connections in XCU-THH area for control & sensor cables

A complete overview of the appliance harnesses and connections can be seen in section 13.2.1

This section (fig 37) explains the signals/wiring that may be required during appliance installation.

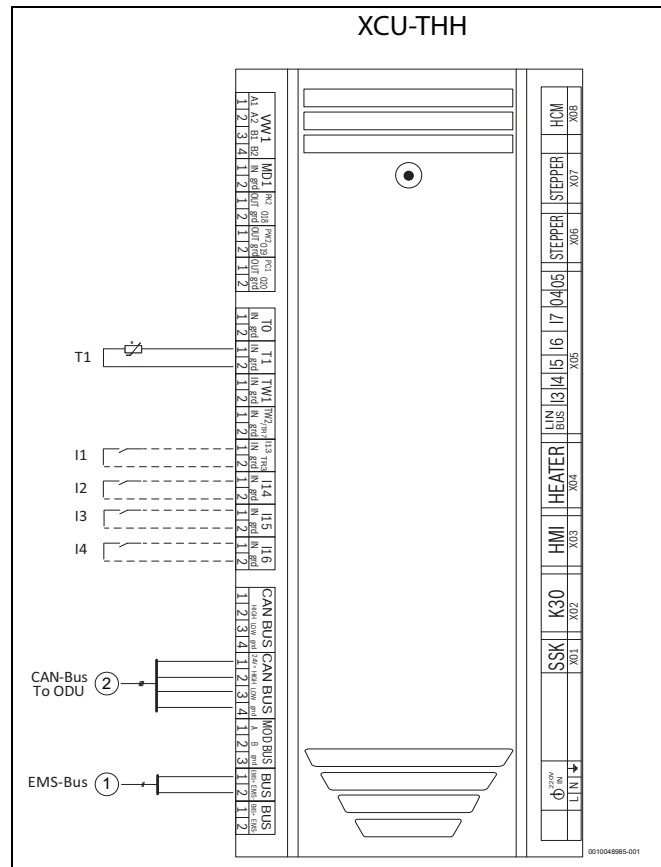

Fig. 37 Connections XCU-THH (XCU HY)

- [I1] (NOT USED)
- [I2] External input 2: Blocks heating or DHW
- [I3] External input 3: Heating circuit overheat protection (safety thermostat)
- [I4] (NOT USED)
- [T1] Temperature sensor outdoor
- [1] EMS-BUS accessory
- [2] CAN-BUS to heat pump



The tightening torque of the screws for the connectors of the XCU-THH must be 0.5Nm.

- ▶ Place a cable tie in front of each XCU-THH (XCU HY) connector.

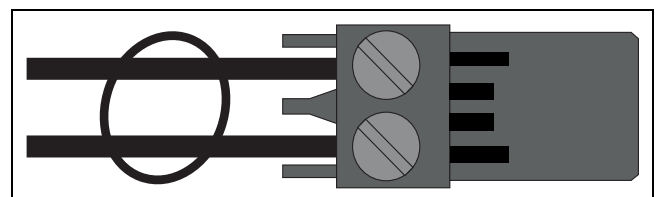

Fig. 38 Cable tie on connector

7.7 Replace cover and final checks

When all required harnesses are fitted or replaced, the appliance can be re-assembled. Ensure the following aspects are carried out and observed:

- ▶ Check connectors are pushed fully home or wires inserted fully into spring activated connectors
- ▶ Ensure cables are not tight, trapped or pass sharp edges
- ▶ Ensure cable(s) pass through the designated strain-relief device
- ▶ Pick up front panel and reconnect earth wire to the tab on the bottom lip
- ▶ Hook front panel on to control box top lips
- ▶ Push front panel towards the two bottom steel clips ensuring earth cable is fully inside the box
- ▶ Fit the two screws through the two bottom steel clips
- ▶ Check cables around appliance and routing outside of appliance
- ▶ Reconnect 230V to both supply cables

8 Commissioning



WARNING

Material damage from frost!

The heating or auxiliary heater may be irreparably damaged by frost.

- ▶ Do not start the indoor unit if there is a possibility of the heating or auxiliary heater being frozen.

The system will be damaged if it is commissioned without water

- ▶ Only operate the device when it is filled with water and at the correct operating pressure.



Do not turn on the indoor unit in case that existing valves to the heating system or to the heat pump are closed.

- ▶ Check that all valves in the system are opened.

When powering up the device, a dry-run check is performed to check if it is filled with water. To avoid false alarms, at least one heating zone must be open when powering on the appliance. The compressor and electric heater is blocked during the dry-run check. The duration of the check is 2 minutes.

- ▶ Check if the valves to, at least, one heating zone are open before powering on the appliance.



Before you turn on the appliance please check that all external connected devices are well earth connected.

8.1 Commissioning checklist

1. Power on the unit.
2. Commission the heating system. Use the control unit to make the necessary settings (→ instructions for control unit).
3. Vent the entire heating system after commissioning.
4. Check that all sensors display the appropriate values.
5. Check and clean the particle filter.
6. Check the operation of the heating system after startup (→ instructions for control unit).

8.2 Commissioning of the control panel

when the control panel is connected to the power supply for the first time, a configuration wizard is launched. Once the wizard is complete, you can either switch to the Start menu or make additional settings in the service menu.



Several functions are only displayed if they have been activated or if the relevant accessories have been installed.

Meu item	Description
Language	Set the language. Press [Next].
Date format	Set the date format. Choose between [DD.MM.YY], [MM/DD/YY] -or- [YY-MM-DD]. Select [Next] to continue with the configuration -or- [Back] to go back.
Date	Set the date. Select [Next] to continue with the configuration -or- [Back] to go back.
Time of Day	Set the time. Select [Next] to continue with the configuration -or- [Back] to go back.
Check installation	Check: are all modules and the remote control installed and addressed? Select [Next] to continue with the configuration -or- [Back] to go back.
Configuration wizard	Start system analysis. The control panel does a check of the system and all connected accessory modules. Select [Next] to continue with the configuration -or- [Back] to go back.
Country	Set the country. Select [Next] to continue with the configuration -or- [Back] to go back.
Min. outside temp.	Set dimensioning outdoor temperature of the system. This is the lowest average outside temperature in the relevant region. The setting affects the slope of the heating curve as it is the point where the heat source reaches the highest flow temperature. Select [Next] to continue with the configuration -or- [Back] to go back.
Fuse ¹⁾	Select the main fuse that protects the heat pump. [16 A] [20 A] [25 A] [32 A]. Select [Next] to continue with the configuration -or- [Back] to go back.

Meu item	Description
Fitting situation	<p>Select the type of house for the system installation. This influences the display of "Away" functions in the system control unit and in the remote control unit (display of system functions outside of the assigned heating circuit). The multi-family house setting prevents, for example, the absence or vacation of one party in the house from influencing the control behaviour of the other party in the house.</p> <ul style="list-style-type: none"> • Single-family home. With this setting, all functions are available in the remote control. • Apartment building. The functions that affect all residents are hidden in the remote control, e.g. settings for hot water, 2nd heating circuit, solar system, the "Away", holiday program. <p>Select [Next] to continue with the configuration -or- [Back] to go back.</p>
Heating system HC1	<p>Select the type of heat distribution in heating circuit 1 [Radiators] [Convectors] [Radiant floor heating]. Select [Next] to continue with the configuration -or- [Back] to go back.</p>
System function HC1	<p>Select the function for heating circuit 1. [Heating] [Cooling] [Heating + Cooling]. Select [Next] to continue with the configuration -or- [Back] to go back.</p>
Heat. system type HC1	<p>Set the maximum flow temperature for heating circuit 1 and confirm.²⁾ Radiators / Convectors Select [Next] to continue with the configuration -or- [Back] to go back.</p>
Design temperature HC1	<p>Set the design flow temperature for heating circuit 1 and confirm. The design temperature is the desired flow temperature at minimum outside temperature. Radiators / Convectors Select [Next] to continue with the configuration -or- [Back] to go back.</p>
System analysis	<p>The configuration wizard has been successfully completed. Save settings and switch to main screen or continue with further settings?. select Save and close if the commissioning is done -or- select Detailed settings to make further settings.</p>

1) This menu is only shown if a power guard is installed.
 2) The maximum temperature setting is depending on the variant of the indoor unit.

Table 11 Configuration wizard

8.3 Heat pump, indoor unit and heating system ventilation

NOTICE

If the system is not correctly ventilated (purged), this will damage the indoor unit!

The auxiliary heater may overheat or be damaged if it has not been fully vented prior to activation.

- ▶ Carefully vent the system when filling.
- ▶ Carefully vent the system once again during commissioning.



Vent also by other ventilation valves in the heating system, e.g. radiators.

1. Connect the power supply to the heat pump and indoor unit.
2. Activate the venting program: > **Service** > **System settings** > **Heat pump** > **Air-purge mode**.
3. Vent by all manual venting valves in the heat pump, indoor unit and heating system.
4. Return to normal operation by closing the function test menu.
5. Clean the particle filter SC1.
6. Check the pressure on the pressure gauge and add more water with the fill valve if the pressure is below 2 bar.
7. Check that the heat pump is running and that there are no active alarms.

Total duration	1,5 minutes					
Duration (s)	15	15	15	15	15	15
PC1	X	X	X			
PC0 (100%)	X	X		X	X	
VW1					X	X

Table 12 Venting program. X = active component

- [PC1] Circulation pump for the heating circuit
- [PC0] Primary circulation pump (heat carrier)
- [VW1] three-way valve heating/DHW cylinder. X= open towards the DHW cylinder

8.4 Operating temperatures



The operating temperature check must be performed in heating mode (not in DHW or cooling mode).

For optimum system operation, the flow rate in the heat pump and heating system must be monitored. This check should be performed after 10 minutes heat pump operating time and during high compressor heating output.

The temperature differential for the heat pump must be set for the different heating systems.

- ▶ With underfloor heating system: set a temperature difference of 4.5 K.
- ▶ With radiators: set a temperature difference of 7.5 K.

These settings are optimal for the heat pump.

Check the temperature differential at high compressor heating output:

- ▶ Tap on the Heat Pump symbol on the display.
- ▶ On the **System overview**, notice the temperatures to and from the heat pump (outdoor unit).
- ▶ Check whether the temperature difference corresponds to the delta value set for heating mode.

If the temperature differential is too large:

- ▶ Vent the heating system.
- ▶ Clean filters / strainers.
- ▶ Check pipe dimensions.

Temperature differential in the heating system

- ▶ Set the output at the heating pump PC1 so that the following difference is achieved:
- ▶ With underfloor heating system: 4.5 K.
- ▶ With radiators: 7.5 K.

8.5 Function test



The compressor is preheated before starting. This can take up to 30 minutes, depending on the outdoor temperature. The prerequisite for starting is that the compressor temperature (TR1) is 20K higher than the supply air temperature (TL2) and 20K lower than the flow temperature from the heat pump (TC3). The set point is limited between 20 °C and 45 °C. The temperatures are displayed in the diagnosis menu of the control unit.

Quick start of the heat pump is only possible when there is an active heat demand.



Repeated use of this function can lead to reduction of compressor lifetime

The manual defrost of the heat pump is only possible when the compressor is running with the 4-way valve in heating mode and the outdoor temperature is below 15 °C.



When the function test menu is activated on the control panel, software restrictions are deactivated (i. e. high temperature protection for under floor heating).

- ▶ Test active components of the system.
- ▶ Check if there is a heating or hot water demand.

-or-

- ▶ Draw off DHW or increase the heating curve to generate demand (→ instructions for control unit).
- ▶ Check whether the heat pump starts.
- ▶ Make sure that no alarms are currently active.

-or-

- ▶ Troubleshooting.
- ▶ Check the operating temperatures (→ instructions for the control unit).

8.5.1 Overheating protection (OHP)

The overheating protection triggers when the temperature of the electric booster heater rises above 88 °C.

- ▶ Make sure that the particle filter is not blocked and that the flow through the heat pump and heating system is unimpeded.
- ▶ Check the operating pressure.
- ▶ Check the heating and DHW settings.
- ▶ Replace electric heater and cover

8.6 Finishing commissioning

8.6.1 Appliance/product guarantee

This appliance/product has a guarantee against faulty materials or workmanship for a period from the date of installation subject to the terms and conditions.

For full terms and conditions, please visit:

www.worcester-bosch.co.uk/guarantee-terms-and-conditions

Guarantee registration

Your appliance/product carries a guarantee against faulty material or manufacture subject to Terms and Conditions.

To read the full Terms & Conditions please visit us on-line at www.worcester-bosch.co.uk/guarantee.

Your statutory rights are not affected by the manufacturer's guarantee

9 Inspection and maintenance

DANGER

Electrical shock!

- ▶ Before working on the electrics, the main power supply must be switched off.

NOTICE

Deformation due to heat!

If the temperature is too high, the insulation (EPP) in the indoor unit deforms.

- ▶ When carrying out brazing work at the cylinder, protect the insulation with a heat resistant cloth or damp cloth.

- ▶ Only use original spare parts!
- ▶ Refer to the spare parts list when ordering spare parts.
- ▶ Replace removed gaskets and O-rings with new ones.

The tasks described below must be carried out during an inspection.

In case of renovation (exchange installation) and a previously dirty system, more frequent cleaning/service may be necessary in the first weeks after installation.

Display activated alarm

- ▶ Check the alarm log (→ instructions for the control device).

Only use Bosch Group original spare parts with this appliance. Non Bosch Group original spare parts will invalidate the guarantee (if applicable) and any warranty.

- ▶ A comprehensive list of appliance spares can be found on the website www.worcester-bosch.co.uk/spares

9.1 Particle and magnetite filter

WARNING

Strong magnet!

Can be harmful to pacemaker wearers.

- ▶ Do not clean the filter or check the magnetite indicator if you have a pacemaker.

The particle filter prevents particles and contamination from entering the heat pump. Over time, the filter can become blocked and must be cleaned.

To clean the filter, the system does not need to be emptied. The filter and shut-off valve are integrated.

As the filter is installed vertically, the PCO pump needs to be running when the lever is closed. Ensure the compressor or additional heater are not running when the lever is closed to avoid damaging components. This can be done by entering the function test and running the PCO pump. Then follow the steps below. Do not enter the function test if the compressor is running!

Cleaning the strainer

- ▶ Close the valve (1).
- ▶ Unscrew the cap (manually) (2).
- ▶ Take out the strainer and clean it by running water over it or by pressure cleaning.
- ▶ Reinstall the strainer. For proper assembly, make sure that the guide bumps fit into the recesses in the valve.

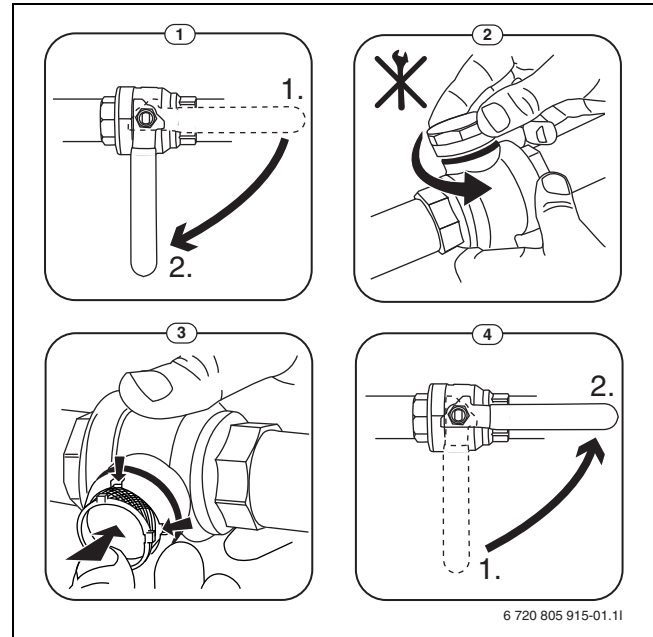

Fig. 39 Cleaning the strainer

- ▶ Screw the cap back on (tighten handtight).
- ▶ Open the valve (4).

Check and clean the particle filter annually.

Check and clean the magnetite filter (if fitted)

Check and clean the magnetite filter 1-2 times a year, but directly after installation and commissioning the filter should be checked and cleaned more frequently. See the instruction that is supplied with the filter for correct procedure.

Check the temperatures of the sensors and record the values

Check temp sensors:

- ▶ T0
- ▶ T1
- ▶ TW1
- ▶ TC0
- ▶ TC1

Check fault history

Check system magnetic filter if there is one fitted.

9.2 DHW expansion vessel & PRVs

Check the operation of the TPRV and the 6 bar PRV, ensure they are safely working and water is transported safely through the tundish and D2 pipework. Check the pressure setting is correct in the DHW expansion vessel.

9.3 Draining of appliance

NOTICE

Material damage due to negative pressure!

Negative pressure can occur during drainage of the appliance.

- ▶ In case the outdoor unit is placed above the indoor unit: vent the outdoor unit during drainage, if the pipework between outdoor unit and indoor unit does not allow negative pressure.
- ▶ Close the valves SC1 and VC3 to the heating system prior to drainage or vent the heating system during drainage.

1. Set the 3-way valve in middle position: > **System settings > Heat pump > 3-way valve in centre pos..**
2. Disconnect the appliance from power.
3. Connect a hose to the drain valve VA0.
4. Open the drain valve and manual air vent valves at the electrical heater and at PC0.

9.4 Shut down the heating system

If the heating system is shut down, there is no frost protection for the appliance.

If the appliance is not in a frost-free room and not in operation, it can freeze in the event of frost.

- ▶ If possible, leave the heating system switched on at all times.
 - or -
- ▶ Drain the primary circuit as well as the heating circuit and drinking water pipes at the lowest point.
 - or -
- ▶ Drain domestic hot water pipes at the lowest point.
- ▶ Mix antifreeze into the heating water and the heat transfer medium.
- ▶ Check if frost protection is ensured by antifreeze according to the instruction of the manufacturers.

10 Troubleshooting

10.1 Operating and fault displays

A fault appears on the display of the user interface. Refer to section 6 Unit troubleshooting in the Installer guide for user interface UI 800 CS (Part No. 6721864855)

11 Environmental protection and disposal

Environmental protection is a fundamental corporate strategy of the Bosch Group.

The quality of our products, their economy and environmental safety are all of equal importance to us and all environmental protection legislation and regulations are strictly observed.

We use the best possible technology and materials for protecting the environment taking account of economic considerations.

Packaging

Where packaging is concerned, we participate in country-specific recycling processes that ensure optimum recycling.

All of our packaging materials are environmentally compatible and can be recycled.

Used appliances

Used appliances contain valuable materials that can be recycled.

The various assemblies can be easily dismantled. Synthetic materials are marked accordingly. Assemblies can therefore be sorted by composition and passed on for recycling or disposal.

Old electrical and electronic appliances



This symbol means that the product must not be disposed of with other waste, and instead must be taken to the waste collection points for treatment, collection, recycling and disposal.

The symbol is valid in countries where waste electrical and electronic equipment regulations apply, e.g. "(UK) Waste Electrical and Electronic Equipment Regulations 2013 (as amended)". These regulations define the framework for the return and recycling of old electronic appliances that apply in each country.

As electronic devices may contain hazardous substances, it needs to be recycled responsibly in order to minimize any potential harm to the environment and human health. Furthermore, recycling of electronic scrap helps preserve natural resources.

For additional information on the environmentally compatible disposal of old electrical and electronic appliances, please contact the relevant local authorities, your household waste disposal service or the retailer where you purchased the product.

You can find more information here:
www.weee.bosch-thermotechnology.com/

Batteries

Batteries must not be disposed together with your household waste. Used batteries must be disposed of in local collection systems.

12 Data Protection Notice



We, **Bosch Thermotechnology Ltd., Cotswold Way, Warndon, Worcester WR4 9SW, United Kingdom**

process product and installation information, technical and connection data, communication data, product registration and client history data to provide product functionality (art. 6 (1) sentence 1 (b) GDPR

/ UK GDPR), to fulfil our duty of product surveillance and for product safety and security reasons (art. 6 (1) sentence 1 (f) GDPR / UK GDPR), to safeguard our rights in connection with warranty and product registration questions (art. 6 (1) sentence 1 (f) GDPR / UK GDPR) and to analyze the distribution of our products and to provide individualized information and offers related to the product (art. 6 (1) sentence 1 (f) GDPR / UK GDPR). To provide services such as sales and marketing services, contract management, payment handling, programming, data hosting and hotline services we can commission and transfer data to external service providers and/or Bosch affiliated enterprises. In some cases, but only if appropriate data protection is ensured, personal data might be transferred to recipients located outside of the European Economic Area and the United Kingdom. Further information are provided on request. You can contact our Data Protection Officer under: Data Protection Officer, Information Security and Privacy (C/ISP), Robert Bosch GmbH, Postfach 30 02 20, 70442 Stuttgart, GERMANY.

You have the right to object, on grounds relating to your particular situation or where personal data are processed for direct marketing purposes, at any time to processing of your personal data which is based on art. 6 (1) sentence 1 (f) GDPR / UK GDPR. To exercise your rights, please contact us via privacy.ttgb@bosch.com To find further information, please follow the QR-Code.

13 Technical Specifications/Logs

13.1 Technical specifications

	Unit	CS5800iAW 180MCP	CS5800iAW 210MP	CS5800iAW 250MP
Electrical information				
Rated voltage	V	230 1N~50Hz		
Fuse class gL/C	A	5 (auxiliary)/16 (electric heater)		
Booster heater	kW	3		
Hot water				
Volume of domestic hot water cylinder	l	166	216	255
Maximum permissible operating pressure in the DHW circuit	bar	10		
Connection	mm	22mm		
Material in the cylinder	-	Stainless steel		
Heating system				
Integrated buffer cylinder volume	l	12		
Type of circulation pump PC1	-	Grundfos UPM4L LIN		
Low energy pump		EEI ≤ 0.20 ¹⁾		
Nominal flow rate	l/s	2)		
Residual head	kPa	2)		
Min./max. operating pressure	kPa	60/250		
Maximum water temperature (flow), booster heater only	°C	75		
Minimum water temperature	°C	5		
Connection (Cu)	mm	Ø 28		
Connection heat transfer medium (Cu)	mm	Ø 28		
Heat transfer medium				
Circulation pump type PC0	-	Grundfos UPM4L LIN		
Low energy pump		EEI ≤ 0.20 ¹⁾		
Nominal flow rate	l/s	2)		
General				
Waste water connection	mm	22mm (tundish connection)		
IP-Rating	IP	X1 D		
Dimensions (width x depth x height)	mm	653 x 645 x 1708	674 x 747x 1561	674 x 747x 1806
Weight excluding packaging	kg	79	83	89
Installation height	m	Up to 2000 m above sea level		

1) Recommended value for the most effective pumps: EEI ≤ 0.20

2) The flow rate and residual head depend on the connected heat pump or in case of hydraulic separation. See the circulation pump diagram.

13.2 Wiring diagram

13.2.1 Wiring diagram of appliance

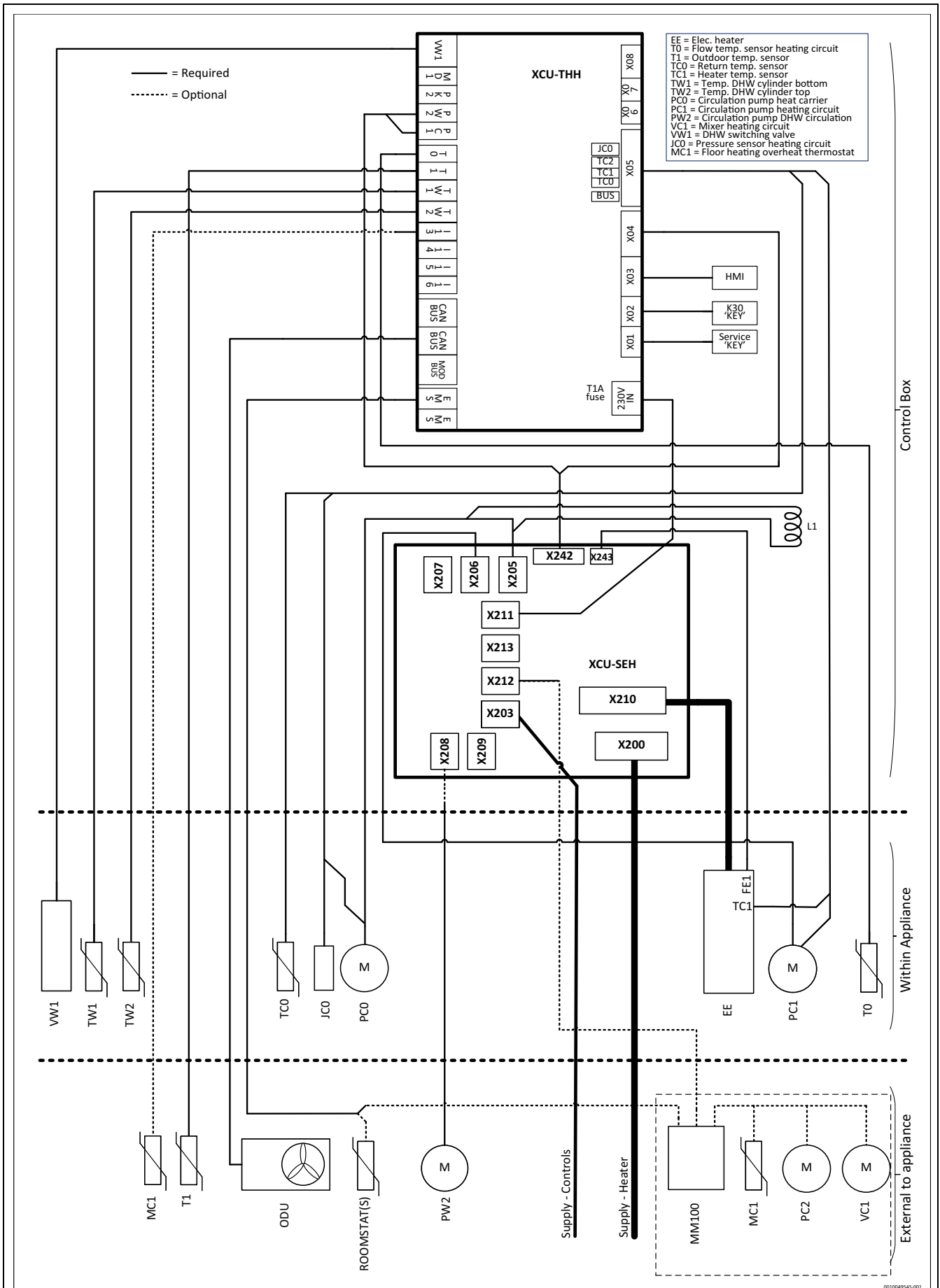

Fig. 40 Wiring diagram of Pre plumbed cylinder CS5800iAW

13.2.2 Cable plan

When extending cables, use the cable types defined in the following tables. All cables must be designed for a temperature range of up to 70 °C.

230V/400V	General	Cross section	Cable type	Maximum length (m)	Connection to terminal
Eheater	Power input	3x 2,5 mm ²	→ table 14		L3 / N / PE
Control unit	Power input	3 x 1.0 mm ² (minimum)	→ table 14		L / N / PE
PW2	Circulation pump DHW	3 x 0.75 mm ² (minimum)	PVC - flexible cable (H07) or H05VV-F 3G 0.75		LSW / N / PE
PK2	Circulation pump, cooling mode	3 x 0.75 mm ² (minimum)	PVC - flexible cable (H07) or H05VV-F 3G 0.75		LSW / N / PE

Table 13 Connections to IDU

2 supply cords		
Function	Electrical heater	Control unit
Cable type	According to local regulations	According to local regulations
Terminals allow use of fine-stranded or solid core wire	3093Y/H05V2V2F to EN50525 heat resistant flexible PVC	3093Y/H05V2v2F to EN50525 heat resistant flexible PVC
Cable diameter	3 x 2,5 mm ²	3 x 1.0mm ²
maximum load ¹⁾	3kW	300W

1) External load to outputs

Table 14 Cable area and cable type

Givare/Bus	General	Minimum cross section	Cable type	Maximum length (m)	Connection XCU-THHpin
T1	Temperature sensor outdoor	< 20m: 0,75 mm ² >20m: 1mm ²	< 20m: LiYY 2x 0,75 >20m: LiYY 2x1	30	T1: 1 / 2
CAN-BUS	Communication line: IDU - ODU	0,75 mm ²	LiYCY (TP) 2 x 2 x 0,75 shielded	30	CAN BUS: 1 / 2 / 3 / 4
EMS-BUS	EMS-BUS: Accessory	0,5 mm ²	LiYY 2 x 0,5 LiYCY 2 x 0,5 shielded		PWR BUS: EMS+ / EMS-

Table 15 Cable plan for sensors and bus cables

13.2.3 Measurements from temperature sensors

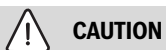

Physical injury or material damage due to incorrect temperature

If sensors with incorrect characteristics are used, the temperatures may be too high or too low.

- Make sure that the temperature sensors used comply with the specified values (see tables below).

°C	Ω	°C	Ω	°C	Ω	°C	Ω
20	12500	40	5323	60	2489	80	1259
25	9999	45	4366	65	2085	85	1073
30	8053	50	3601	70	1754	90	918.7
35	6527	55	2986	75	1483	-	-

Table 16 Sensor T0, TC0, TC1, TW1, TW2

°C	Ω	°C	Ω	°C	Ω
- 40	162100	5	12000	50	1686
- 35	116600	10	9393	55	1398
- 30	84840	15	7405	60	1165
- 25	62370	20	5879	65	975.3

°C	Ω	°C	Ω	°C	Ω
- 20	46320	25	4700	70	820.7
- 15	34740	30	3782	75	693.9
- 10	26290	35	3063	80	589.4
- 5	20080	40	2496	85	502.9
0	15460	45	2046	90	430.8

Table 17 Sensor T1

13.3 Hydraulic configuration



The product must only be installed according to the manufacturer's official system solutions. Other system solutions are not permitted. Liability is voided in the case of damage and problems resulting from impermissible installation.

13.3.1 Heating circuit without mixer

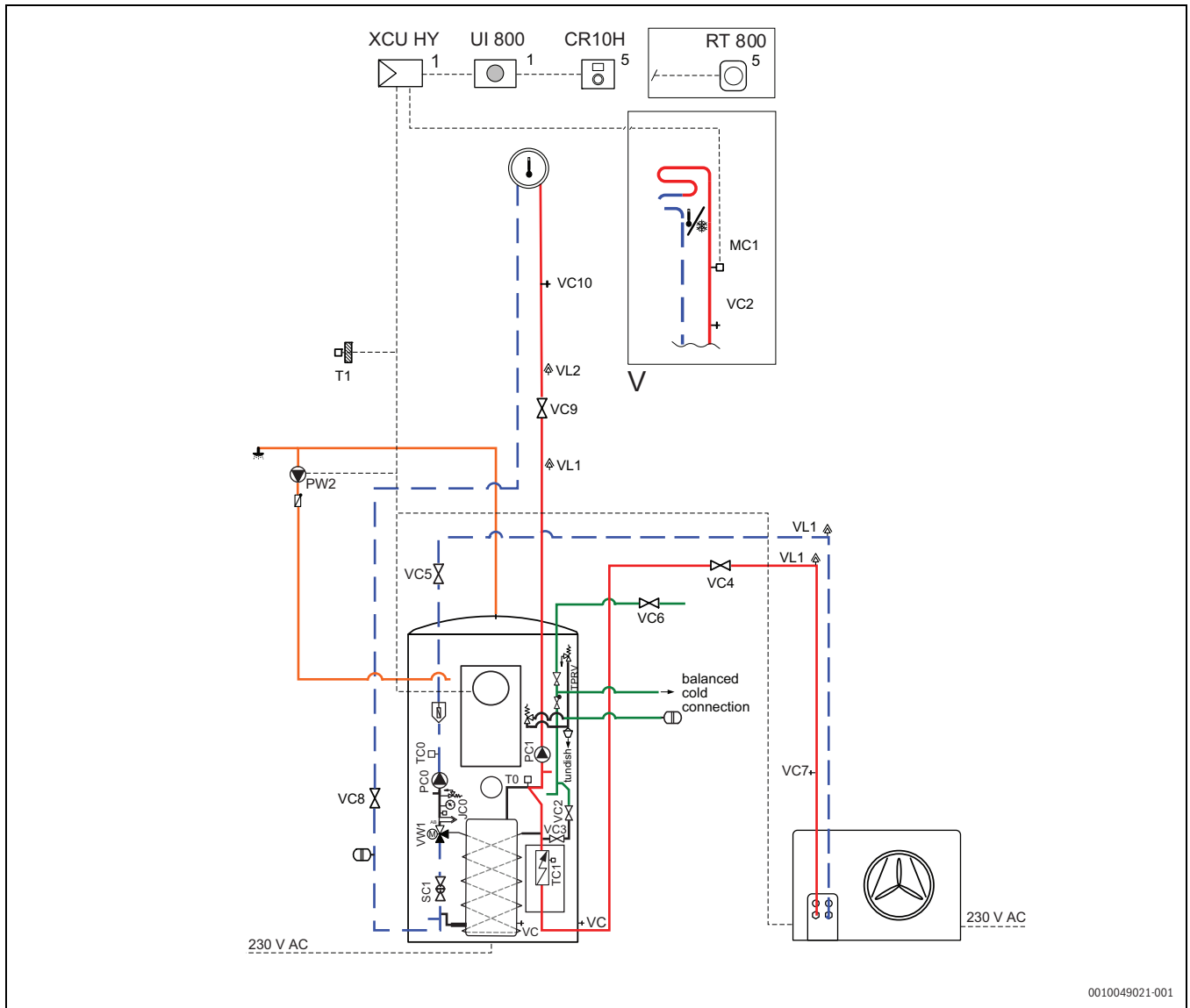

0010049021-001

Fig. 41 Indoor unit Tower, Heat pump (ODU), one unmixed heating circuit

- [1] Mounted in the indoor unit
- [5] Mounted on the wall

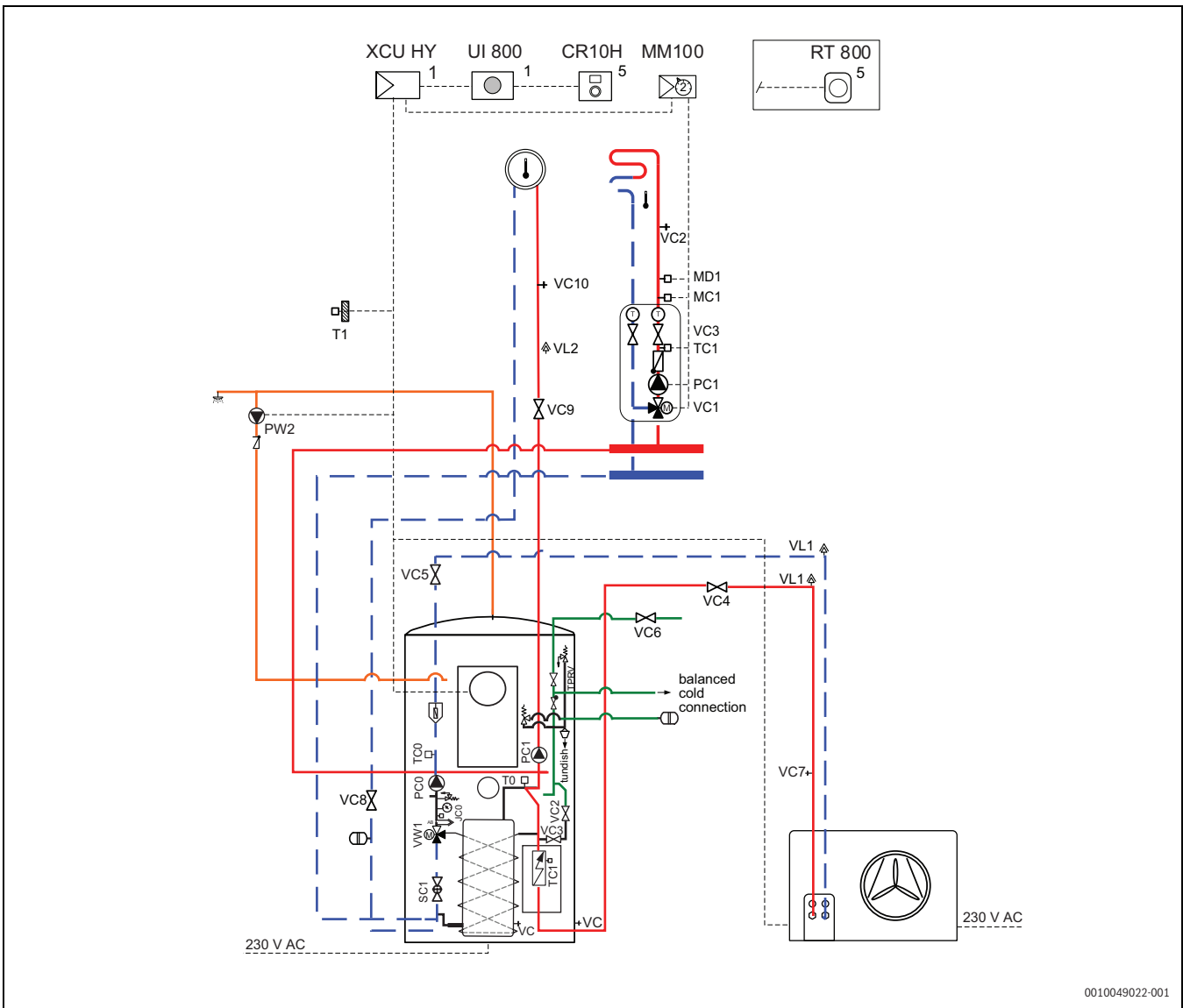

0010049022-001

Fig. 42 Indoor unit, heat pump (ODU), one unmixed and one mixed heating circuit

- [1] Mounted in the indoor unit
- [5] Mounted on the wall

13.3.2 Explanation of symbols















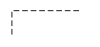

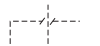







































Symbol	Description	Symbol	Description	Symbol	Description
Pipework/cables					
	Flow - heating/solar		Brine circuit out		DHW circulation
	Return - heating/solar		Potable water		Electrical Wiring
	Brine flow		Hot water		Electrical wiring with break
Mixing valves/valves/temperature sensors/pumps					
	Valve		Differential pressure regulator		Pump
	Revision bypass		Water pressure relief valve		Non-return valve
	Flow regulating valve		Safety assembly		Temperature sensor / switch
	Overcurrent valve		3-way mixing valve (mixing/distribution)		High limit safety cut-out
	Filter shut-off valve		DHW mixer, thermostatic		Flue gas temperature sensor / switch
	Cap valve		3-way mixing valve (changeover)		Flue gas temperature limiter
	Valve, motorized		3-way mixing valve (change over, de-energised when closed to II)		Outdoor ambient temperature sensor
	Valve, thermal		3-way mixing valve (change over, de-energised when closed to A)		Wireless outside temperature sensor
	Shut-off valve, magnetically controlled		4-way mixing valve		...wireless...
Miscellaneous					
	Thermometer		Drain outlet with siphon		Low loss header with sensor
	Pressure gauge		System separation according to EN1717		heat exchanger
	Filling/draining		Expansion vessel with cap valve		Volumetric flow rate measuring device
	Water filter		Magnetite separator		Water sink
	Heat meter		Air separator		Heat. circ.
	DHW outlet		Automatic air vent valve		Underfloor heating circuit
	Relay		Expansion joint		Low-loss header
	Immersion heater				

Table 18 Hydraulic symbols

13.3.3 Performance charts for circulation pumps

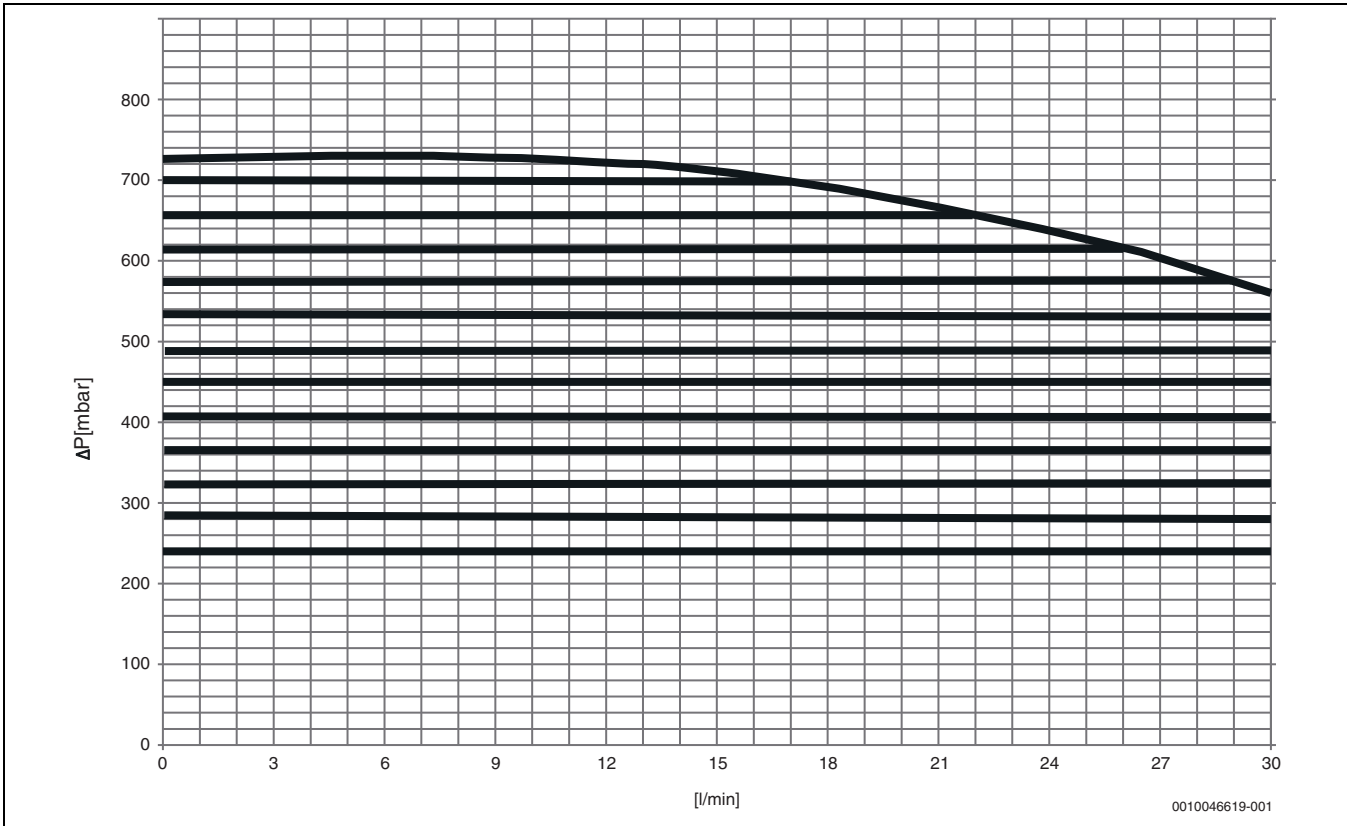

Fig. 43 Performance chart for PC1

Benchmark Commissioning & Warranty Validation Service Record

It is a requirement that the heat pump is installed and commissioned to the manufacturers' instructions and the data fields on the commissioning checklist completed in full.

To instigate the warranty the heat pump needs to be registered with the manufacturer within one month of the installation. The warranty rests with the end-user (consumer), and they should be made aware it is ultimately their responsibility to register with the manufacturer, within the allotted time period.

It is essential that the heat pump is serviced in line with the manufacturers' recommendations, at least annually. This must be carried out by a competent, certified operative. The service details should be recorded on the Benchmark Service and Interim Heat Pump Work Record and left with the householder. Failure to comply with the manufacturers' servicing instructions and requirements will invalidate the warranty.



www.hhic.co.uk

This Commissioning Checklist is to be completed in full by the competent person who commissioned the heat pump and associated equipment as a means of demonstrating compliance with the appropriate Building Regulations and then handed to the customer to keep for future reference.

Failure to install and commission according to the manufacturers' instructions and complete this Benchmark Commissioning Checklist will invalidate the warranty. This does not affect the customer's statutory rights.

* All installations in England and Wales must be notified to Local Authority Building Control (LABC) either directly or through a Competent Persons Scheme. A Building Regulations Compliance Certificate will then be issued to the customer.

© Heating and Hotwater Industry Council (HHIC)



www.hhic.org.uk
Issue date: 20.08.2020

AIR TO WATER HEAT PUMP COMMISSIONING CHECKLIST

Address:											
Heat Pump make and model:											
Heat Pump serial number:											
Commissioned by (PRINT NAME):						Certified Operative Reg number (1):					
Company name:						Telephone number:					
Company email:						Company address:					
										Commissioning date:	
Heating and hot water system complies with the appropriate Building Regulations?											Yes
DNO notification?											Yes
Building Regulations Notification Number (if applicable) (2)											
MCS installer registration Number (if applicable)						MCS product certification number (if applicable)					
F-gas certification number (split heat pump only)											
G3 certification number (if applicable)											
Heat Pump Type (Tick)			Split			Monoblock			Peak heat loss of building kW		
Is Heat Pump Installed as part of a cascade?			Yes			Cascade Heat Pump Series			() of ()		
Heat Pump Refrigerant Type						Refrigerant weight (total)			kg		
Electrical and Hydronic Controls – SYSTEM AND HEAT PUMP (Tick the appropriate boxes)											
Time and temperature control to heating			Room thermostat and programmer/timer			Programmable Roomstat					
			Load/weather compensation			Optimum start control					
Time and temperature control to hot water			Cylinder thermostat and programmer/timer			Combined with Heat pump main controls					
Hybrid system – synchronised control of boiler and heat pump fitted											Yes
If Yes – boiler model switching point – (Quote Tariff or Temperature Level)											
Heating zone valves (including underfloor loops)			pre-existing			Fitted			Not required		
Hot water zone valves			pre-existing			Fitted			Not required		
Thermostatic radiator valves			pre-existing			Fitted			Not required		
Outdoor Sensor			pre-existing			Fitted			Not required		
Heat Pump Safety Interlock (3)			pre-existing			Fitted			Not required		
Automatic bypass to system			pre-existing			Fitted			Not required		
Buffer Vessel Fitted			Yes			No			If yes volume: Litres		
Plate Heat Exchanger fitted to give hydronic separation of the heat pump circuit to the heating circuit											Yes
Expansion vessel for heating is sized, fitted & charged in accordance with manufacturer's instructions											Yes
Legionella protection for stored hot water provided by timed temperature control?											Yes
Water Treatment – SYSTEM AND HEAT PUMP (Tick the appropriate boxes/Measure and Record)											
System has been cleaned and treated in accordance with BS 7593:2019 and heat pump manufacturers' instructions?											Yes
What system cleaner was used?			Brand:			Product:					
What heating system inhibitor was used?			Brand:			Product:					
What heat pump system anti-freeze/inhibitor was used? (monoblock only)			Brand:			Product:			% concentration		
System filter fitted in accordance with BS7593 : 2019?											Yes
Heat Pump outdoor unit (Tick the appropriate boxes/Measure and Record)											
Is the heating system adequately frost protected and pipes insulated to prevent heat loss?											Yes
Split only: The refrigerant circuit has been evacuated and charged in accordance with manufacturer's instructions											Yes
The heat pump is fitted on a solid/stable surface capable of taking its weight											Yes
The necessary heat pump defrost provision been put in place											Yes
The heat pump fan free from obstacles and operational											Yes
Condensate drain installed to manufacturer's instructions											Yes
CENTRAL HEATING MODE (Tick the appropriate boxes/Measure and Record)											
The heating system has been filled and pressure tested											Yes
Heating Flow Temperature			°C			Heating Return Temperature			°C		
System correctly balance/rebalanced											Yes
DOMESTIC HOT WATER MODE (Tick the appropriate boxes)											
Is the heat pump connected to a hot water cylinder?											Unvented
											Vented
											Thermal Store
											Not connected
Hot water cylinder size			Litres			Stored hot water temperature			°C		
Hot water has been checked at all outlets			Yes			Have Thermostatic Blending Valves been fitted?			Yes		
											Not required

* All installations in England and Wales must be notified to Local Authority Building Control (LABC) either directly or through a Competent Persons Scheme. A Building Regulations Compliance Certificate will then be issued to the customer.

© Heating and Hotwater Industry Council (HHIC)



www.hhic.org.uk
Issue date: 20.08.2020

ADDITIONAL SYSTEM INFORMATION (Tick the appropriate boxes/Measure and Record)						
Water flow rate setting of the heat pump at commissioning (l/min):						
Additional heat sources connected:	<input type="checkbox"/>	Gas Boiler	<input type="checkbox"/>	Oil Boiler	<input type="checkbox"/>	Electric Heater
	<input type="checkbox"/>		<input type="checkbox"/>		<input type="checkbox"/>	Solar Thermal
	<input type="checkbox"/>				<input type="checkbox"/>	Other:
ALL INSTALLATIONS						
All electrical work complies with the appropriate Regulations						Yes
The heat pump and associated products have been installed and commissioned in accordance with the manufacturer's instructions						Yes
The operation of the heat pump and system controls have been demonstrated to and understood by the customer						Yes
The manufacturer's literature, including Benchmark Checklist and Service Record, has been explained and left with the customer						Yes
Commissioning Engineer's signature:						
Customer's signature (To confirm satisfactory demonstration and receipt of manufacturers' literature)						

* All installations in England and Wales must be notified to Local Authority Building Control (LABC) either directly or through a Competent Persons Scheme. A Building Regulations Compliance Certificate will then be issued to the customer.

© Heating and Hotwater Industry Council (HHIC)



www.hhic.org.uk
Issue date: 20.08.2020

SERVICE RECORD

It is recommended that your heating system is serviced regularly and that the appropriate Service Interval Record is completed.

Service provider

Before completing the appropriate Service Record below, please ensure you have carried out the service as described in the manufacturer's instructions. Always use the manufacturer's specified spare part when replacing controls.

*A System inhibitor efficacy test is required on every annual service in accordance with the manufacturers' instructions and BS 7593. It is only acceptable to not have undertaken this if the service engineers attendance visit was in between annual services to attend a non-water facing component.

SERVICE/INTERIM WORK		Date:	
Engineer name:			
Company name:			
Telephone No:			
Operative ID No:			
System inhibitor concentration has been checked and appropriate action taken, in accordance with BS 7593 and heat pump manufacturers' instructions. *		Yes	N/a
Comments:			
.....			
.....			
.....			
.....			
.....			
Signature:			

SERVICE/INTERIM WORK		Date:	
Engineer name:			
Company name:			
Telephone No:			
Operative ID No:			
System inhibitor concentration has been checked and appropriate action taken, in accordance with BS 7593 and heat pump manufacturers' instructions. *		Yes	N/a
Comments:			
.....			
.....			
.....			
.....			
.....			
Signature:			

SERVICE/INTERIM WORK		Date:	
Engineer name:			
Company name:			
Telephone No:			
Operative ID No:			
System inhibitor concentration has been checked and appropriate action taken, in accordance with BS 7593 and heat pump manufacturers' instructions. *		Yes	N/a
Comments:			
.....			
.....			
.....			
.....			
.....			
Signature:			

SERVICE/INTERIM WORK		Date:	
Engineer name:			
Company name:			
Telephone No:			
Operative ID No:			
System inhibitor concentration has been checked and appropriate action taken, in accordance with BS 7593 and heat pump manufacturers' instructions. *		Yes	N/a
Comments:			
.....			
.....			
.....			
.....			
.....			
Signature:			

SERVICE/INTERIM WORK		Date:	
Engineer name:			
Company name:			
Telephone No:			
Operative ID No:			
System inhibitor concentration has been checked and appropriate action taken, in accordance with BS 7593 and heat pump manufacturers' instructions. *		Yes	N/a
Comments:			
.....			
.....			
.....			
.....			
.....			
Signature:			

SERVICE/INTERIM WORK		Date:	
Engineer name:			
Company name:			
Telephone No:			
Operative ID No:			
System inhibitor concentration has been checked and appropriate action taken, in accordance with BS 7593 and heat pump manufacturers' instructions. *		Yes	N/a
Comments:			
.....			
.....			
.....			
.....			
.....			
Signature:			

* All installations in England and Wales must be notified to Local Authority Building Control (LABC) either directly or through a Competent Persons Scheme. A Building Regulations Compliance Certificate will then be issued to the customer.

© Heating and Hotwater Industry Council (HHIC)



www.hhic.org.uk
Issue date: 20.08.2020

SERVICE RECORD

It is recommended that your heating system is serviced regularly and that the appropriate Service Interval Record is completed.

Service provider

Before completing the appropriate Service Record below, please ensure you have carried out the service as described in the manufacturer's instructions.

Always use the manufacturer's specified spare part when replacing controls.

*A System inhibitor efficacy test is required on every annual service in accordance with the manufacturers' instructions and BS 7593. It is only acceptable to not have undertaken this if the service engineers attendance visit was in between annual services to attend a non-water facing component.

SERVICE/INTERIM WORK		Date:	
Engineer name:			
Company name:			
Telephone No:			
Operative ID No:			
System inhibitor concentration has been checked and appropriate action taken, in accordance with BS 7593 and heat pump manufacturers' instructions. *	Yes	N/a	
Comments:			
.....			
.....			
.....			
.....			
.....			
.....			
Signature:			

SERVICE/INTERIM WORK		Date:	
Engineer name:			
Company name:			
Telephone No:			
Operative ID No:			
System inhibitor concentration has been checked and appropriate action taken, in accordance with BS 7593 and heat pump manufacturers' instructions. *	Yes	N/a	
Comments:			
.....			
.....			
.....			
.....			
.....			
.....			
Signature:			

SERVICE/INTERIM WORK		Date:	
Engineer name:			
Company name:			
Telephone No:			
Operative ID No:			
System inhibitor concentration has been checked and appropriate action taken, in accordance with BS 7593 and heat pump manufacturers' instructions. *	Yes	N/a	
Comments:			
.....			
.....			
.....			
.....			
.....			
.....			
Signature:			

SERVICE/INTERIM WORK		Date:	
Engineer name:			
Company name:			
Telephone No:			
Operative ID No:			
System inhibitor concentration has been checked and appropriate action taken, in accordance with BS 7593 and heat pump manufacturers' instructions. *	Yes	N/a	
Comments:			
.....			
.....			
.....			
.....			
.....			
.....			
Signature:			

* All installations in England and Wales must be notified to Local Authority Building Control (LABC) either directly or through a Competent Persons Scheme. A Building Regulations Compliance Certificate will then be issued to the customer.

© Heating and Hotwater Industry Council (HHIC)



www.hhic.org.uk
Issue date: 20.08.2020

Bosch Thermotechnik GmbH
Junkersstrasse 20-24
73249 Wernau, Germany
www.bosch-homecomfortgroup.com

GB Importer:
Bosch Thermotechnology Ltd.
Cotswold Way, Warndon
Worcester WR4 9SW, United Kingdom